



## LABORATORY MANUAL

**B.Tech. Semester- I/ II**

**WORKSHOP PRACTICES LAB**

**Subject code: MEE-101P**

**Prepared by:**

Prof. Rajesh Mattoo

**Checked by:**

Prof. Megha Goel

**Approved by:**

Name : Prof. (Dr.) Isha Malhotra

**Sign.: .....**

**Sign.: .....**

**Sign.: .....**

**DEPARTMENT OF APPLIED SCIENCE & HUMANITIES  
DRONACHARYA COLLEGE OF ENGINEERING  
KHENTAWAS, FARRUKH NAGAR, GURUGRAM (HARYANA)**

## **Table of Contents**

1. Vision and Mission of the Institute
2. Vision and Mission of the Department
3. Program Educational Objectives (PEOs)
4. Program Outcomes (POs)
5. Program Specific Outcomes (PSOs)
6. University Syllabus
7. Course Outcomes (COs)
8. Course Overview
9. List of Experiments
10. DOs and DON'Ts
11. General Safety Precautions
12. Guidelines for students for report preparation
13. Lab assessment criteria
14. Lab Experiments

## **Vision and Mission of the Institute**

### **Vision:**

“To impart Quality Education, to give an enviable growth to seekers of learning, to groom them as World Class Engineers and managers competent to match the expending expectations of the Corporate World has been ever enlarging vision extending to new horizons of Dronacharya College of Engineering.”

### **Mission:**

**M1.** To prepare students for full and ethical participation in a diverse society and encourage lifelong learning by following the principle of ‘Shiksha evam Sahayata’ i.e. Education & Help.

**M2.** To impart high-quality education, knowledge and technology through rigorous academic programs, cutting-edge research, & Industry collaborations, with a focus on producing engineers & managers who are socially responsible, globally aware, & equipped to address complex challenges.

**M3.** Educate students in the best practices of the field as well as integrate the latest research into the academics.

**M4.** Provide quality learning experiences through effective classroom practices, innovative teaching practices and opportunities for meaningful interactions between students and faculty.

**M5.** To devise and implement program of education in technology that are relevant to the changing needs of society, in terms of breadth of diversity and depth of specialization.

## **Vision and Mission of the Department**

### **Vision:**

To lay a strong foundation for the first year students of the engineering discipline in the area of Applied Sciences and Humanities with a view to make them capable of innovating and inventing engineering solutions and also develop students as capable and responsible citizens of our nation.

### **Mission:**

- To build strong fundamental knowledge and ability for application in students and make them capable to apply knowledge of mathematics and science to the solution of complex engineering problems.
- To impart knowledge, leading to understanding between engineering and other core areas of Applied Sciences and Humanities.
- To provide students the basic tools of analysis, as well as the knowledge of the principles on which engineering is based.
- To strive to inculcate the scientific temper and the spirit of enquiry in the students.
- To make students achieve a superior level in communication and presentation skills.
- To foster values and ethics and make students responsible citizens of India.
- To pursue inter-disciplinary research for the larger good of the society.

## **Program Educational Objectives (PEOs)**

**PEO1:** To provide students with a sound knowledge of mathematical, scientific and engineering fundamentals required to solve real world problems.

**PEO2:** To develop research oriented analytical ability among students and to prepare them for making technical contribution to the society.

**PEO3:** To develop in students the ability to apply state-of-the-art tools and techniques for designing software products to meet the needs of Industry with due consideration for environment friendly and sustainable development.

**PEO4:** To prepare students with effective communication skills, professional ethics and managerial skills.

**PEO5:** To prepare students with the ability to upgrade their skills and knowledge for life-long learning.

### Program Outcomes (POs)

**PO1:** Engineering knowledge: Apply the knowledge of mathematics, science, engineering fundamentals, and an engineering specialization to the solution of complex engineering problems.

**PO2:** Problem analysis: Identify, formulate, review research literature, and analysis complex engineering problems reaching substantiated conclusions using first principles of mathematics, natural sciences, and engineering sciences.

**PO3:** Design/development of solutions: Design solutions for complex engineering problems and design system components or processes that meet the specified needs with appropriate consideration for the public health and safety, and the cultural, societal, and environmental considerations.

**PO4:** Conduct investigations of complex problems: Use research-based knowledge and research methods including design of experiments, analysis and interpretation of data, and synthesis of the information to provide valid conclusions.

**PO5:** Modern tool usage: Create, select, and apply appropriate techniques, resources, and modern engineering and IT tools including prediction and modelling to complex engineering activities with an understanding of the limitations.

**PO6:** The engineer and society: Apply reasoning informed by the contextual knowledge to assess societal, health, safety, legal and cultural issues and the consequent responsibilities relevant to the professional engineering practice.

**PO7:** Environment and sustainability: Understand the impact of the professional engineering solutions in societal and environmental contexts, and demonstrate the knowledge of, and need for sustainable development.

**PO8:** Ethics: Apply ethical principles and commit to professional ethics and responsibilities and norms of the engineering practice.

**PO9:** Individual and team work: Function effectively as an individual, and as a member or leader in diverse teams, and in multidisciplinary settings.

**PO10:** Communication: Communicate effectively on complex engineering activities with the engineering community and with society at large, such as, being able to comprehend and write effective reports and design documentation, make effective presentations, and give and receive clear instruction.

**PO11:** Project management and finance: Demonstrate knowledge and understanding of the engineering and management principles and apply these to one's own work, as a member and leader in a team, to manage projects and in multidisciplinary environments.

**PO12:** Life-long learning: Recognize the need for, and have the preparation and ability to engage in independent and life-long learning in the broadest context of technological change.

## **Program Specific Outcomes (PSOs)**

**PSO1:** Analyze, identify and clearly define a problem for solving user needs by selecting, creating and evaluating a computer-based system through an effective project plan.

**PSO2:** Design, implement and evaluate processes, components and/or programs using modern techniques, skills and tools of core Information Technologies to effectively integrate secure IT-based solutions into the user environment.

**PSO3:** Develop impactful IT solutions by using research-based knowledge and research methods in the fields of integration, interface issues, security & assurance and implementation.

## **University Syllabus**

**Introduction:**

Introduction to Manufacturing Processes and their Classification, Introduction to additive manufacturing, Industrial Safety.

**Machining Shop:**

Lathe, description of lathe: headstock, tailstock, gearbox, carriage, apron, cutting speed, feed & depth of cut, cutting tools, Chucks: 3 jaw, 4 jaw.

**Fitting Shop:**

Introduction, classification of metals: ferrous and nonferrous, fitting tools: measuring and marking tools, marking schemes for a fitting jobs, cutting tools.

**Carpentry Shop:**

Introduction of carpentry, types of woods, carpentry tools: measuring tools, marking tools, cutting tools: saws, chisels, planing tools, drilling tools, striking tools, wood working joints, wood working lathe.

**Foundry Shop:**

Introduction, foundry hand tools, measuring boxes, ladle, moulding, furnaces, Pattern: Types of Pattern and Allowances

**Welding Shop:**

Introduction to welding, Classification of Welding Processes, Arc welding & Gas welding equipment's.



## WORKSHOP PRACTICES (MEE-101P)

### Course Outcomes (COs)

Upon successful completion of the course, the students will be able to:

**CO1:** To impart fundamental knowledge of engineering practices such as fitting, wood working foundry, machining, welding etc. For manufacturing a product.

**CO2:** To prepare the students to understand the various tool.

**CO3:** To prepare the students to understand the equipment's used in these processes and there working principle.

**CO4:** To impart fundamental knowledge of lath machine.

**CO5:** To able to understand the basic knowledge of various welding processes.

### CO-PO Mapping

	PO1	PO2	PO3	PO4	PO5	PO6	PO7	PO8	PO9	PO10	PO11	PO12
CO1				2	3		2		1		2	1
CO2			1		3		2		1		2	1
CO3				2	3		2		1		2	1
CO4	1			2	3		2		1		2	1
CO5			2	2	3		2		1		2	1
<b>CO</b>	<b>0.2</b>		<b>0.6</b>	<b>1.6</b>	<b>3</b>		<b>2</b>		<b>1</b>		<b>2</b>	<b>1</b>

### CO-PSO Mapping

	PSO1	PSO2	PSO3
CO1		2	2
CO2		2	2
CO3		2	2
CO4		2	2
CO5		2	2
<b>CO</b>		<b>2</b>	<b>2</b>

## **WORKSHOP PRACTICES (MEE-101P)**

---

### **Course Overview**

Workshop practice is the backbone of the real industrial environment which helps to develop and enhance relevant technical hand skills required by the technician working in the various engineering industries and workshops. Workshop practice gives the basic working knowledge required for the production of various engineering products. It explains the construction, function, use and application of different working tools, equipment, machines as well as the technique of manufacturing a product from its raw material.

## WORKSHOP PRACTICES (MEE-101P)

### List of Experiments mapped with COs

S.no.	List of Experiments	Course Outcome	Page Number
1.	To study different types of measuring tools used in metrology and determine least counts of vernier calipers, micrometers and vernier height gauges.	CO2	1-6
2.	To study different types of machine tools (lathe, shaper or Planer or slotter, milling, drilling machines).	CO2	7-10
3.	To prepare a job on a lathe involving facing, outside turning, taper turning, step turning, radius making and Parting-off.	CO2	11-13
4.	To study different types of fitting tools and marking tools Used in fitting practice.	CO3	14-16
5.	To prepare lay out on a metal sheet by making and prepare rectangular tray, pipe shaped components e.g. funnel.	CO3	17-20
6.	To prepare joints for welding suitable for butt welding and Lap welding.	CO2	21-23
7.	To perform pipe welding.	CO4	24-26
8.	To study various types of carpentry tools and prepares impieties of at least two wooden joints.	CO5	27-30
9.	To prepare simple engineering components/shapes by forging.	CO5	31-33
10.	To prepare mold and core assembly, to put metal in the mold and fettle the casting.	CO4	34-36

## **DOs and DON'Ts**

### **Dos**

1. Work deliberately and carefully.
2. Keep your work area clean.
3. Students must wear college uniform and carry their college ID.
4. Students should have separate note book for practical.
5. Students should have their own pencil, eraser, scale, along with pen and lab note book.
6. Handle the equipment /models carefully.

### **DON'Ts**

1. Do not wander around the room, distract other students, startle other students or interfere with the laboratory experiments of others.
2. Do not eat food, drink beverages or chew gum in the laboratory.
3. Do not open any irrelevant internet sites on lab computer.

## **General Safety Precautions**

### **Precautions (In case of Injury or Electric Shock)**

1. To break the victim with live electric source, use an insulator such as fire wood or plastic to break the contact. Do not touch the victim with bare hands to avoid the risk of electrifying yourself.
2. Unplug the risk of faulty equipment. If main circuit breaker is accessible, turn the circuit off.
3. If the victim is unconscious, start resuscitation immediately, use your hands to press the chest in and out to continue breathing function. Use mouth-to-mouth resuscitation if necessary.
4. Immediately call medical emergency and security. Remember! Time is critical; be best.

### **Precautions (In case of Fire)**

1. Turn the equipment off. If power switch is not immediately accessible, take plug off.
2. If fire continues, try to curb the fire, if possible, by using the fire extinguisher or by covering it with a heavy cloth, if possible, isolate the burning equipment from the other surrounding equipment.
3. Sound the fire alarm by activating the nearest alarm switch located in the hallway.
4. Call security and emergency department immediately:

**Emergency: Reception**

**Security: Main Gate**

## **Guidelines to students for report preparation**

All students are required to maintain a record of the experiments conducted by them. Guidelines for its preparation are as follows: -

- 1) All files must contain a title page followed by an index page. *The files will not be signed by the faculty without an entry in the index page.*
- 2) Student's Name, Roll number and date of conduction of experiment must be written on all pages.
- 3) For each experiment, the record must contain the following
  - (i) Aim/Objective of the experiment
  - (ii) Pre-experiment work (as given by the faculty)
  - (iii) Lab assignment questions and their solutions
  - (iv) Test Cases (if applicable to the course)
  - (v) Results/ output

**Note:**

1. Students must bring their lab record along with them whenever they come for the lab.
2. Students must ensure that their lab record is regularly evaluated.

## WORKSHOP PRACTICES (MEE-101P)

### Lab Assessment Criteria

An estimated 10 lab classes are conducted in a semester for each lab course. These lab classes are assessed continuously. Each lab experiment is evaluated based on 5 assessment criteria as shown in following table. Assessed performance in each experiment is used to compute CO attainment as well as internal marks in the lab course.

<b>Grading Criteria</b>	<b>Exemplary (4)</b>	<b>Competent (3)</b>	<b>Needs Improvement (2)</b>	<b>Poor (1)</b>
<b>AC1: Pre-Lab written work (this may be assessed through viva)</b>	Complete procedure with underlined concept is properly written	Underlined concept is written but procedure is incomplete	Not able to write concept and procedure	Underlined concept is not clearly understood
<b>AC2: Program Writing/ Modeling</b>	Assigned problem is properly analyzed, correct solution designed, appropriate language constructs/ tools are applied, Program/solution written is readable	Assigned problem is properly analyzed, correct solution designed, appropriate language constructs/ tools are applied	Assigned problem is properly analyzed & correct solution designed	Assigned problem is properly analyzed
<b>AC3: Identification &amp; Removal of errors/ bugs</b>	Able to identify errors/ bugs and remove them	Able to identify errors/ bugs and remove them with little bit of guidance	Is dependent totally on someone for identification of errors/ bugs and their removal	Unable to understand the reason for errors/ bugs even after they are explicitly pointed out
<b>AC4: Execution &amp; Demonstration</b>	All variants of input /output are tested, Solution is well demonstrated and implemented concept is clearly explained	All variants of input /output are not tested, However, solution is well demonstrated and implemented concept is clearly explained	Only few variants of input /output are tested, Solution is well demonstrated but implemented concept is not clearly explained	Solution is not well demonstrated and implemented concept is not clearly explained
<b>AC5: Lab Record Assessment</b>	All assigned problems are well recorded with objective, design constructs and solution along with Performance analysis using all variants of input and output	More than 70 % of the assigned problems are well recorded with objective, design contracts and solution along with Performance analysis is done with all variants of input and output	Less than 70 % of the assigned problems are well recorded with objective, design contracts and solution along with Performance analysis is done with all variants of input and output	

# LAB EXPERIMENTS



# WORKSHOP PRACTICES (MEE-101P)

---

## LAB EXPERIMENT 1

### OBJECTIVE

To study different types of measuring tools used in metrology and determine least counts of vernier calipers, micrometers and vernier height gauges.

### PROCEDURE

Describe in brief the following measuring tools with neat sketch mentioning their sizes & usage.

1. Vernier caliper
2. Micrometer (inside & outside)
3. Vernier height gauge
4. Vernier depth gauge
5. Standard wire gauge
6. Combination set
7. Screw thread gauge
8. Depth micrometer
9. Radius gauge
10. Caliper
11. Try square
12. Sine bar
13. Bevel protector
14. Dial indicator

### LEAST COUNT

Least count of vernier caliper, micrometer, & vernier height gauge to be calculated.

### PRECAUTIONS

1. Measuring tools should not be mishandled.
2. Proper upkeep of measuring tool is necessary must be cleaned.
3. Tools before & after use kept in store
4. Tools should be calibrated after certain interval & accuracy determined.

MEASURING TOOLS

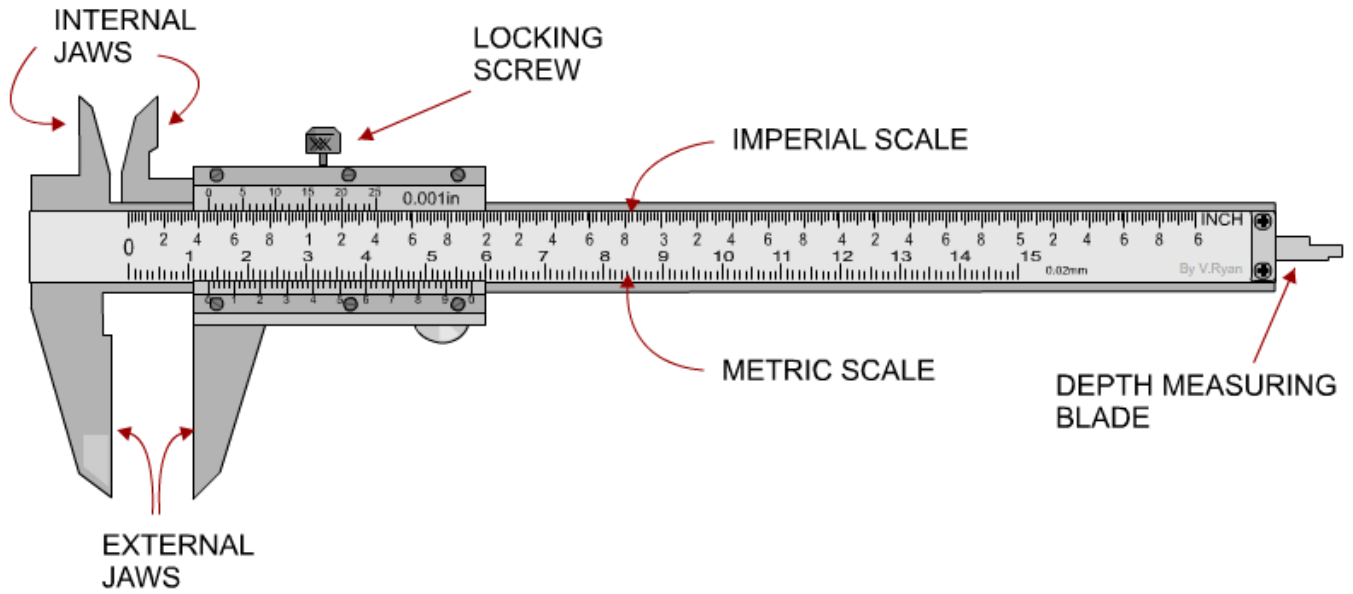

Fig: Vernier Caliper

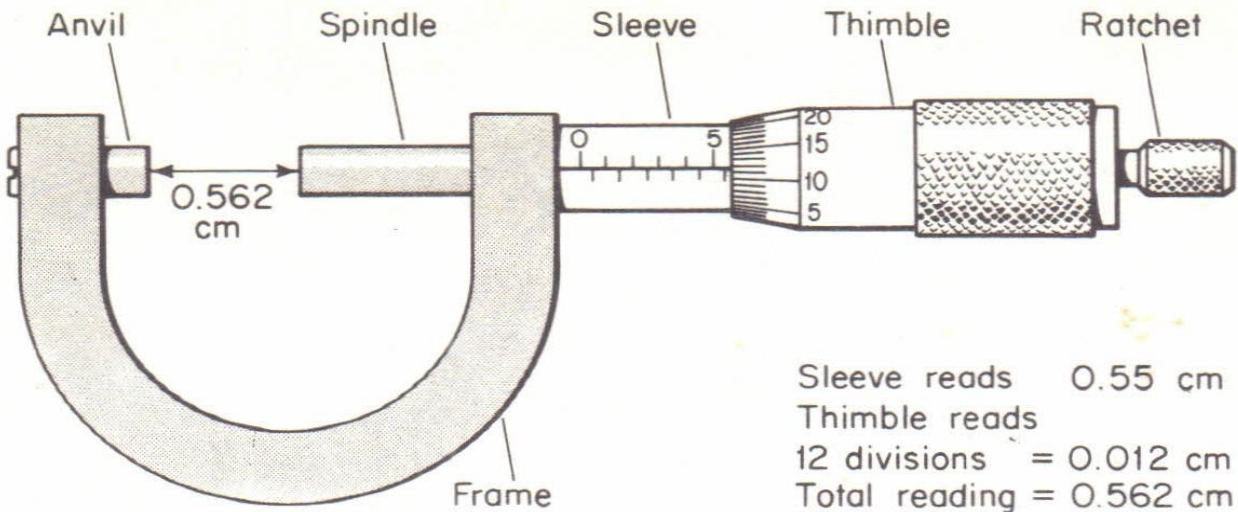
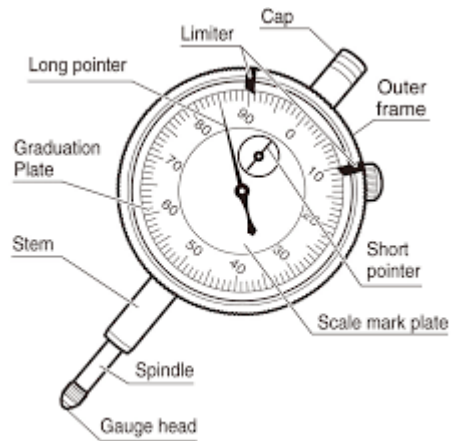
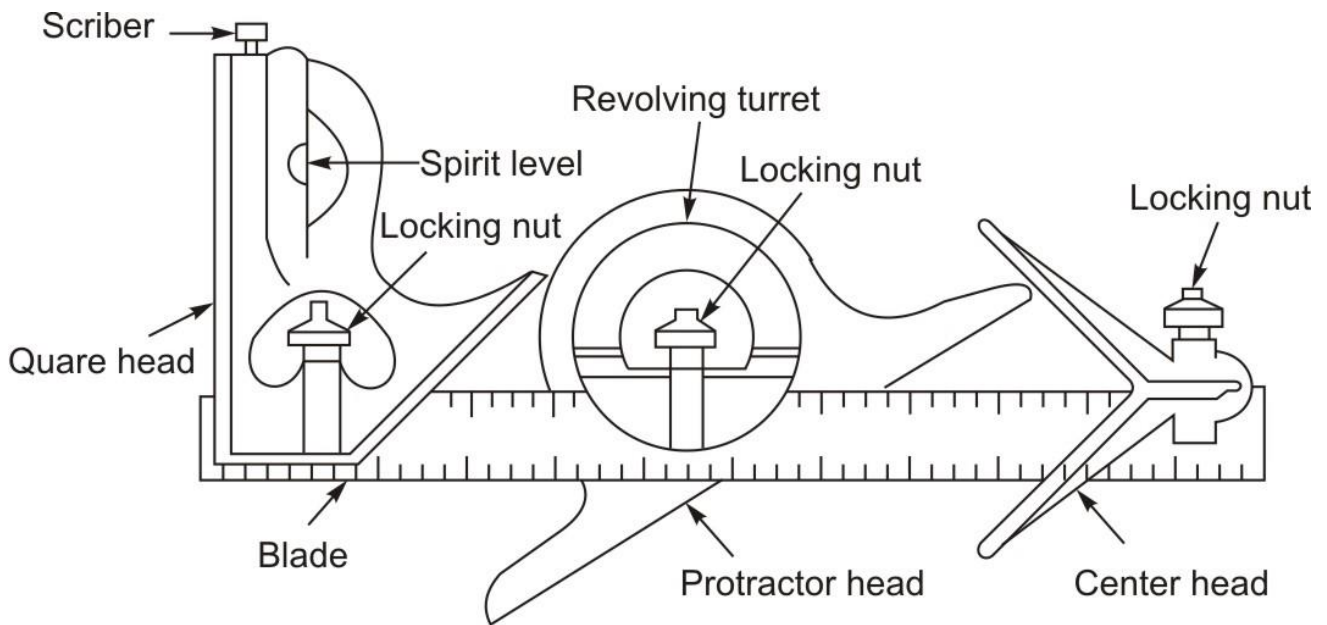

Fig: Micrometre Screw Guage



**Fig: Dial Indicator**



**Fig: Combination Set**

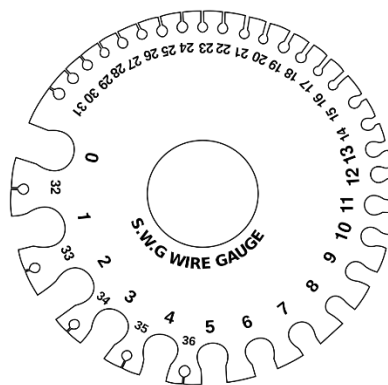

**Fig: Wire Gauge**

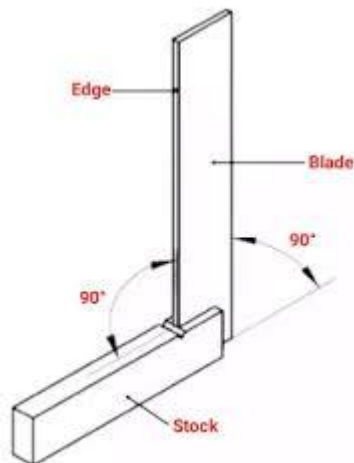

**Fig: Try Square**

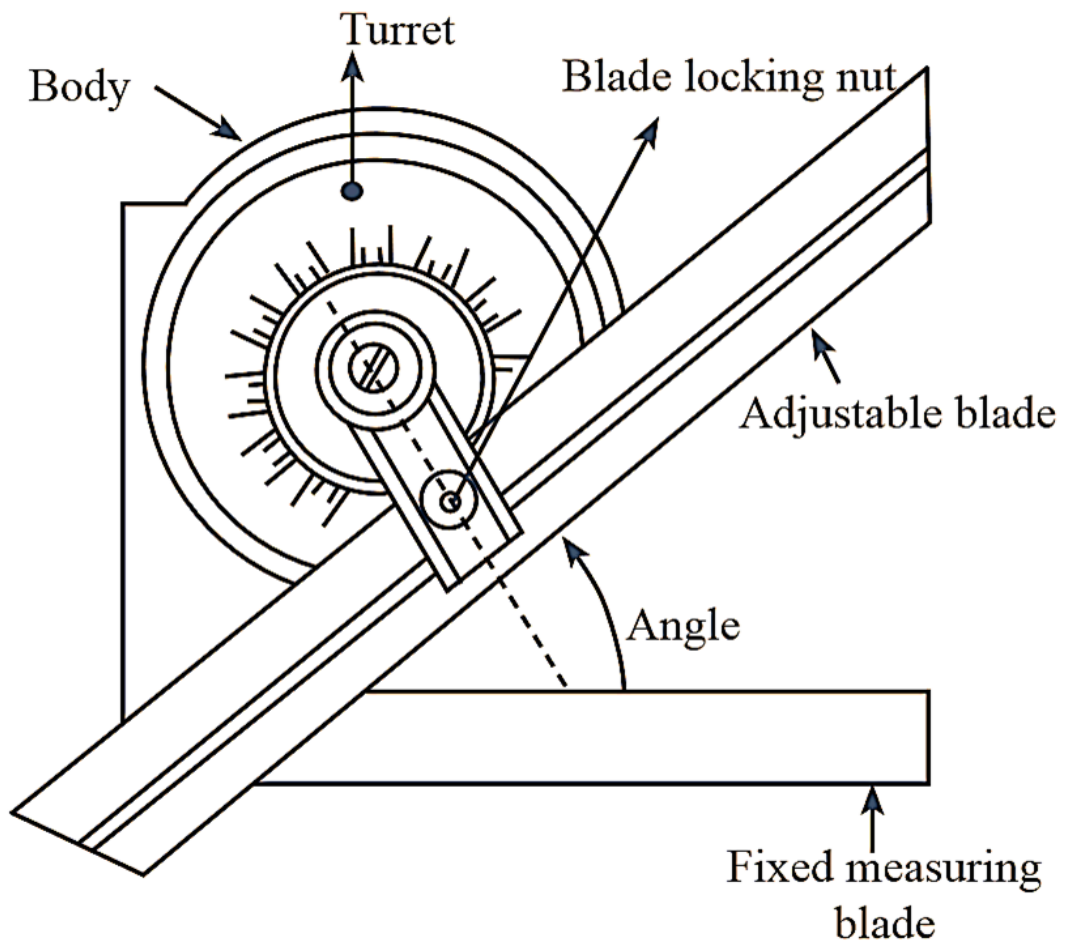

**Fig: Bevel Protector**



**Fig: Steel Rule**



**Fig: Divider**



**Fig: Inside and Outside Calliper**

## WORKSHOP PRACTICES (MEE-101P)

---

### QUIZ QUESTIONS WITH ANSWERS:

**Q1.** What is a Vernier caliper?

**Ans:** A Vernier caliper is a measuring tool used to measure linear dimensions with high precision. It consists of a main scale and a sliding Vernier scale that allows for more accurate readings.

**Q2.** What is a micrometre?

**Ans:** A micrometer, also known as a micrometer screw gauge, is a precise measuring tool used to measure small distances or thicknesses. It utilizes a calibrated screw mechanism and an associated scale to provide precise readings.

**Q3.** What is a dial indicator?

**Ans:** A dial indicator is a measuring tool that uses a dial or needle to display linear measurements. It is commonly used in engineering and manufacturing to measure small distances, displacements, or deviations.

**Q4.** What is a height gauge?

**Ans:** A height gauge is a tool used to measure the height of objects or the vertical distance between surfaces. It typically consists of a base, a vertical measuring scale, and a sliding horizontal arm with a probe or scriber.

**Q5.** What is a depth gauge?

**Ans:** A depth gauge is a measuring tool used to measure the depth of holes, slots, or recesses. It often consists of a rod or probe that can be inserted into the measured feature, along with a scale or digital display for reading the depth.

**Q6.** What is a feeler gauge?

**Ans:** A feeler gauge is a thin strip of metal or plastic with precise thickness markings used to measure gaps or clearances. It is commonly used in automotive and mechanical applications to check tolerances or set clearances.

**Q7.** What is a caliper gauge?

**Ans:** A caliper gauge, also known as a caliper-type thickness gauge, is a tool used to measure the thickness of objects. It typically has two jaws or measuring surfaces that can be adjusted to grip the material being measured.

**Q8.** What is a tape measure?

**Ans:** A tape measure is a flexible measuring tool used to measure longer distances. It typically consists of a long ribbon of metal or plastic marked with linear measurements, encased in a retractable housing for easy storage.

**Q9.** What is an angle gauge?

**Ans:** An angle gauge, also called a protractor or bevel gauge, is a tool used to measure or set angles. It typically consists of a flat base and a rotating arm or scale with angle markings, allowing for accurate angle measurements.

## LAB EXPERIMENT 2

### OBJECTIVE

To study different types of machine tools (lathe, shaper or planer or slotter, milling, drilling machines).

### PROCEDURE

1. Neat diagram of following machine tools to be drawn.
2. Brief description of the machine tools to be given.
3. Important parts to be labeled & marked.
4. Accessories should be indicated.
5. Different function of the machine tool can perform to be described.

### MACHINE TOOLS

1. Different types of lathe.
2. Different types of drilling machine.
3. Different types of milling machine e.g. horizontal, vertical, universal.
4. Shaper
5. Planer
6. Slotter

### PRECAUTIONS

1. How various operations can be performed on a particular machine tool and the precautions required for that to be remembered.
2. Upkeep & usual maintenance of the machine tools must be well understood

MACHINE TOOLS

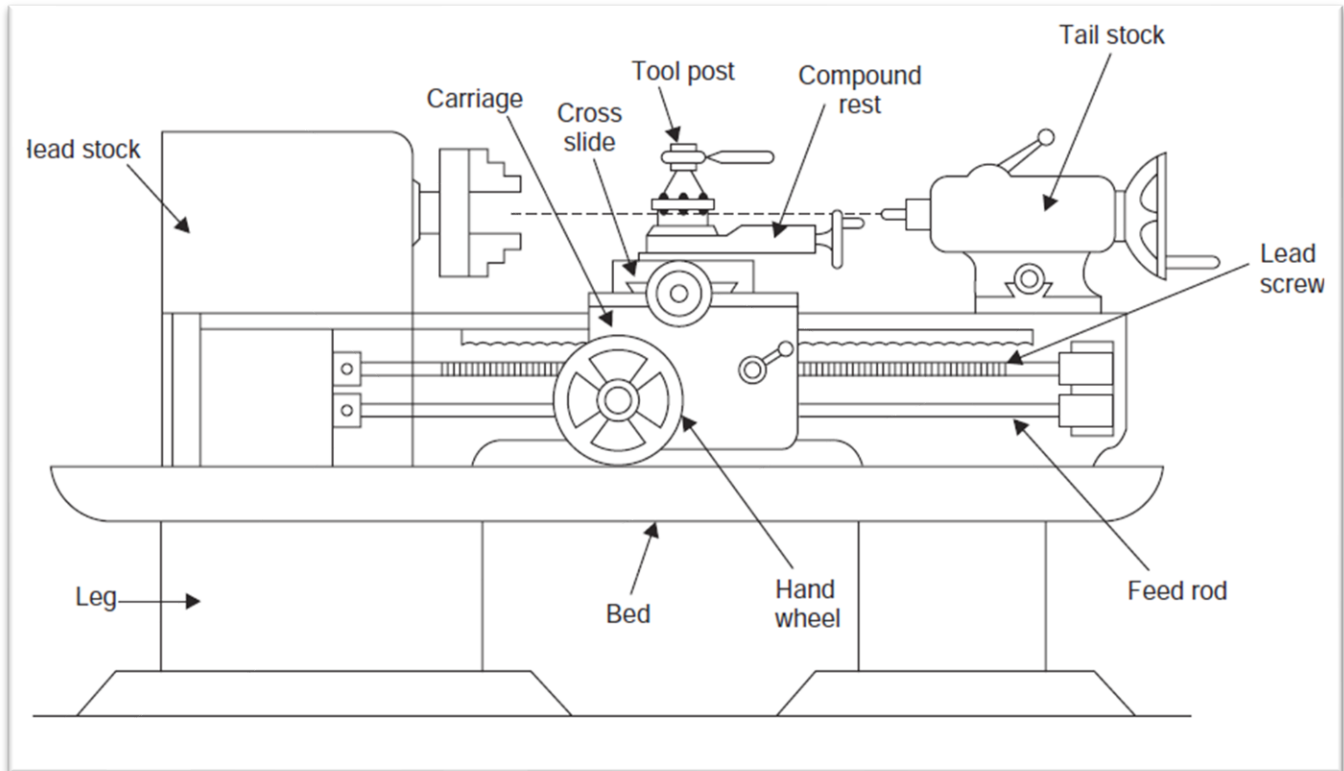

Fig: Lathe Machine

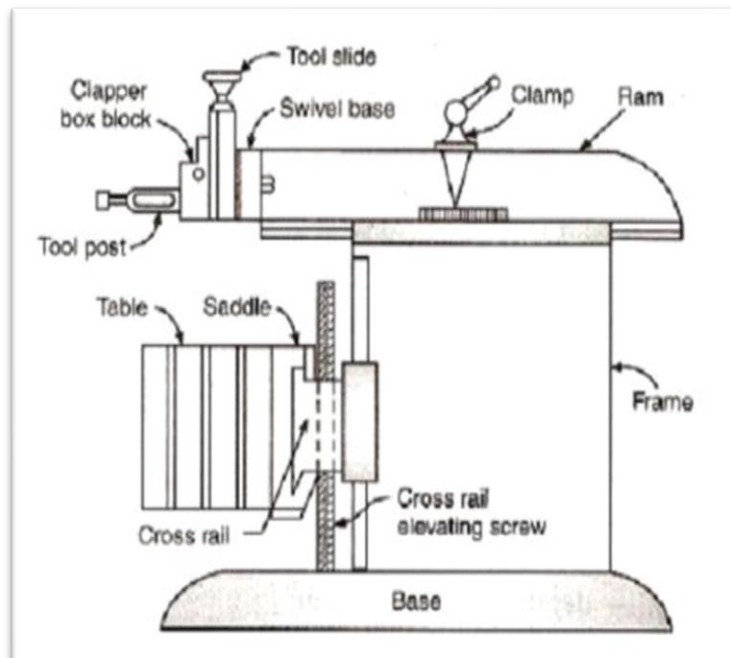
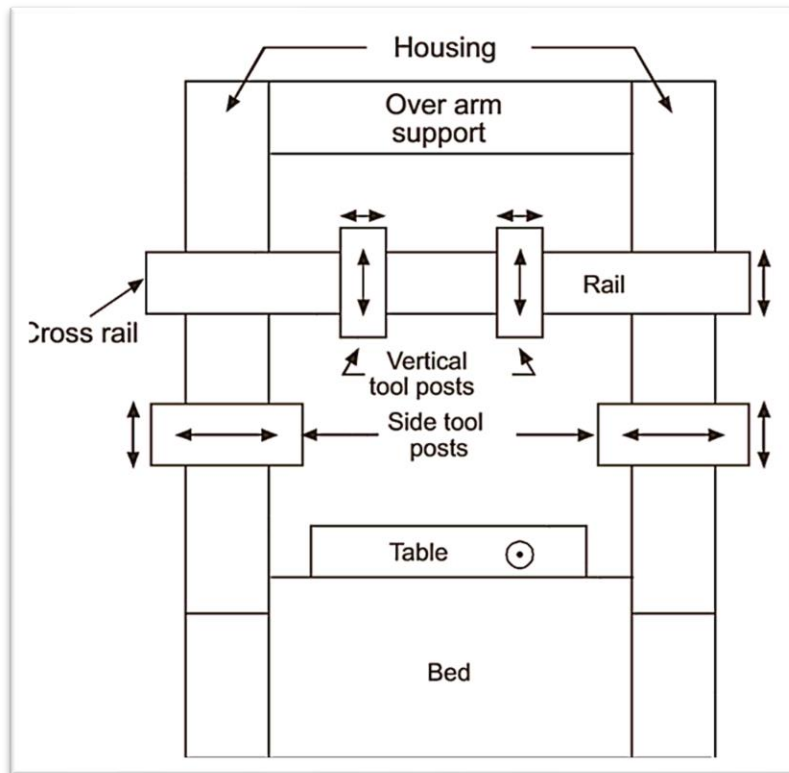
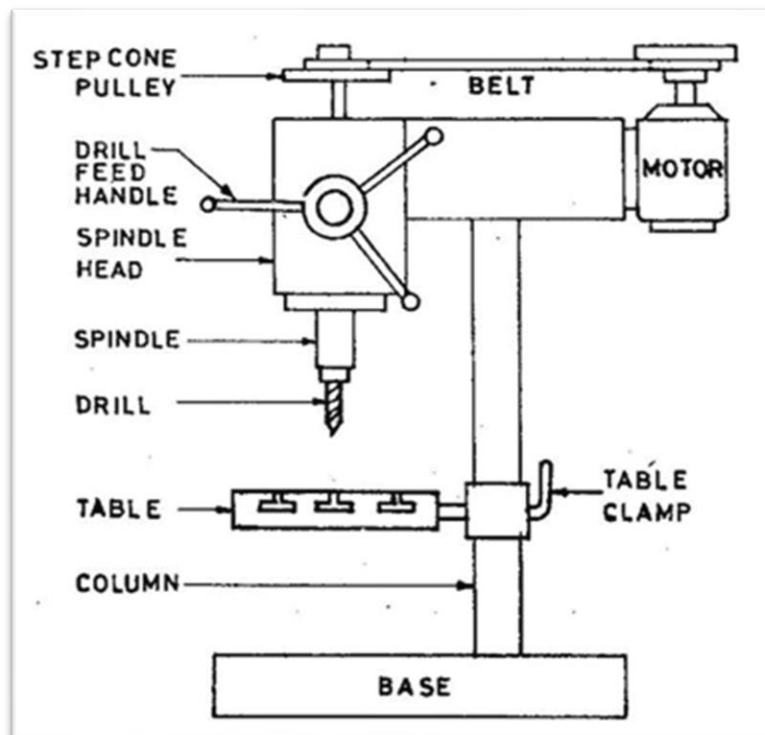

Fig: Shaper Machine





**Fig: Planner Machine**



**Fig: Drilling Machine**

## WORKSHOP PRACTICES (MEE-101P)

---

### QUIZ QUESTIONS WITH ANSWERS:

**Q1.** What is a lathe?

**Ans:** A lathe is a machine tool used for shaping or machining cylindrical workpieces. It rotates the workpiece while a cutting tool is applied to shape it into the desired form.

**Q2.** What is a milling machine?

**Ans:** A milling machine is a machine tool that uses rotating cutters to remove material from a workpiece. It can perform a variety of operations, including cutting, drilling, and shaping, to produce complex shapes and parts.

**Q3.** What is a drilling machine?

**Ans:** A drilling machine, also known as a drill press, is a machine tool used for creating holes in various materials. It utilizes a rotating drill bit and applies vertical pressure to penetrate the workpiece.

**Q4.** What is a grinding machine?

**Ans.** A grinding machine is a machine tool used for grinding or smoothing surfaces through abrasive wheel or belt grinding methods. It is commonly used for precision grinding, sharpening, or removing excess material.

**Q5.** What is a bandsaw?

**Ans:** A bandsaw is a machine tool used for cutting various materials using a continuous band of toothed metal, known as a bandsaw blade. It is particularly useful for cutting curves or irregular shapes.

**Q6.** What is a CNC machine?

**Ans:** A CNC (Computer Numerical Control) machine is a machine tool controlled by a computer program. It can automatically execute complex machining operations with high precision, based on the instructions provided in the program.

**Q7.** What is a lathe machine?

**Ans:** A lathe machine, or simply a lathe, is a machine tool used for shaping or machining cylindrical workpieces. It rotates the workpiece while a cutting tool is applied to shape it into the desired form.

**Q8.** What is a shaping machine?

**Ans:** A shaping machine, also known as a shaper, is a machine tool used for generating flat or curved surfaces. It uses a reciprocating cutting tool to remove material and create the desired shape.

**Q9.** What is a milling cutter?

**Ans:** A milling cutter is a rotary cutting tool used in milling machines. It has multiple cutting edges and teeth that remove material as the cutter rotates, allowing for precise cutting and shaping operations.

**Q10.** What is a power press?

**Ans:** A power press is a machine tool used for various forming and stamping operations. It uses mechanical or hydraulic force to shape or cut materials, often used in industries such as metalworking and manufacturing.

**LAB EXPERIMENT 3**

**OBJECTIVE:**

To prepare a job on a lathe involving facing, outside turning, taper turning, step turning, radius making and parting-off.

**TOOLS REQUIRED**

Single point cutting tool, radius tool, parting tool.

**MATERIAL REQUIRED**

Mild steel rod.

**INSTRUMENT REQUIRED**

Steel rule, vernier caliper, out side caliper, sine bar.

**PROCEDURE**

1. Job is fixed in three jaw chuck for proper alignment.
2. Single point cutting tool is fixed in the tool post and facing operation is completed.
3. A rough cut is used to turn the outer periphery.
4. Final turning and step turning operation are completed in sequence.
5. The compound slide is set at the taper angle as per calculation with the center line and tapering operation is completed through different cuts.
6. Radius tool is fixed in tool post for making radius and the operation is completed.
7. For maintaining the proper length of the job parting off tool is used and parting operation is completed.

**PRECAUTIONS**

1. Work piece should be firmly gripped in the three jaw chuck.
2. Coolant is to be used.
3. Hand gloves and apron must be used while working.
4. Proper rpm should be selected before the operation.

## WORKSHOP PRACTICES (MEE-101P)

---

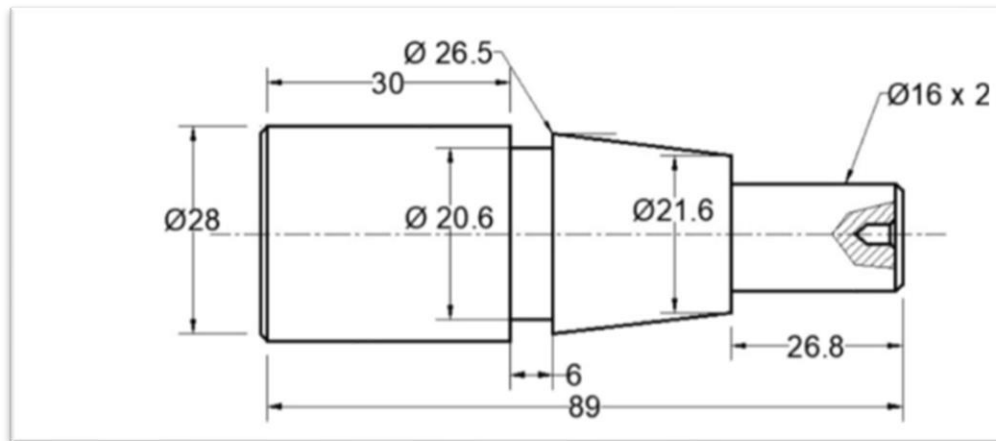

**Fig: Lathe Job**

### QUIZ QUESTIONS WITH ANSWERS:

**Q1.** What is a single point cutting tool?

**Ans:** A single point cutting tool is a tool used in machining operations to remove material from a workpiece. It typically has one cutting edge or point and is commonly used in turning, boring, and facing operations on a lathe or milling machine.

**Q2.** What is a radius tool?

**Ans:** A radius tool is a cutting tool designed to create a specific curved or rounded shape, known as a radius, on a workpiece. It is often used in machining operations to create fillets or rounded edges.

**Q3.** What is a parting tool?

**Ans:** A parting tool, also called a cutoff tool, is a cutting tool used to create a groove or separate a workpiece into two or more parts. It is commonly used in machining operations to cut off or separate material during turning or milling processes.

**Q4.** How does a single point cutting tool work?

**Ans:** A single point cutting tool works by rotating the workpiece against the tool's cutting edge or point. As the tool engages with the workpiece, it removes material through a shearing action, resulting in the desired shape or dimension.

**Q5.** Where are radius tools commonly used?

**Ans:** Radius tools are commonly used in machining operations that require curved surfaces or rounded edges. They are often used in applications such as creating fillets, chamfers, or rounded corners on workpieces.

**Q6.** What are the different types of parting tools?

**Ans:** Parting tools come in various shapes and sizes depending on the specific application. Some common types include straight parting tools, grooving tools, and parting-off blades for lathe machines.

## WORKSHOP PRACTICES (MEE-101P)

---

**Q7.** What are the materials used for single point cutting tools?

**Ans:** Single point cutting tools are typically made from high-speed steel (HSS), carbide, or ceramic materials. Each material has different properties that make it suitable for specific machining applications.

**Q8.** What factors should be considered when selecting a single point cutting tool?

**Ans:** When selecting a single point cutting tool, factors such as material being machined, cutting speed, depth of cut, and desired surface finish should be considered. These factors help determine the appropriate tool material, tool geometry, and cutting parameters.

**Q9.** How is a parting tool different from other cutting tools?

**Ans:** A parting tool is specifically designed for cutting or separating a workpiece into multiple parts, whereas other cutting tools are typically used for shaping or removing material. Parting tools often have a narrow cutting edge and are capable of creating deep grooves or separating workpieces completely.

# WORKSHOP PRACTICES (MEE-101P)

## LAB EXPERIMENT 4

### OBJECTIVE:

To prepare lay out on a metal sheet by making and prepare rectangular tray, pipe shaped components e.g. funnel.

### TOOLS REQUIRED

Scale, scribe, snip, bench shearing machine, mallet, surface plate, rail line, pipe stake, combination plier, bench vice, funnel stake, setting hammer, Ball peen hammer.

### MATERIAL REQUIRED

G.I. (galvanized iron) sheet 26 SWG.

### PROCEDURE FOR TRAY MAKING

1. Sheet of required size is cut and smoothed by using mallet.
2. Layout of the tray is drawn on the sheet as per pattern using the scribe.
3. Four corners are cut as per marking using straight snip.
4. Edges are folded to make the beading on all four sides.
5. Bending of all four sides are done at right angles opposite the beading and bend corners using mallet.
6. Then the tray is finished.

### PROCEDURE FOR PIPE MAKING

1. The sheet of required size is cut and marked for lock grooved joint.
2. Edges are folded for joint.
3. Bending of the piece is done using pipe stake and mallet.
4. The job is finished using mallet, combination plier and setting hammer.

### PRECAUTIONS

1. Be careful and attentive while working on metal sheet.
2. Wear, apron, shoes, gloves and tight fitted clothes.
3. Use proper tools for each operation.

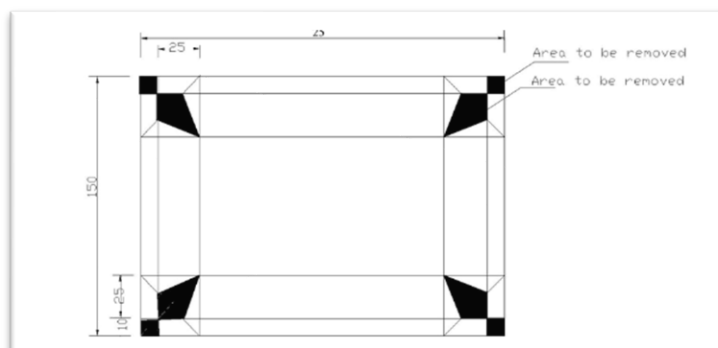

**Fig: Sheet Metal Job**

## WORKSHOP PRACTICES (MEE-101P)

---

### QUIZ QUESTIONS WITH ANSWERS:

**Q1.** What is a metal sheet?

**Ans:** A metal sheet is a flat, thin piece of metal that is typically rectangular in shape. It is commonly made from materials such as steel, aluminium, or stainless steel and is used in various industries for construction, fabrication, and manufacturing purposes.

**Q2.** What are the common thicknesses of metal sheets?

**Ans:** Metal sheets come in a range of thicknesses, commonly measured in gauge or millimetres. Common thicknesses for metal sheets can vary depending on the specific application, but typical ranges include 18 gauge (1.2 mm) to 30 gauge (0.25 mm) for steel sheets and 0.2 mm to 6 mm for aluminium sheets.

**Q3.** What are the different types of metal sheets?

**Ans:** There are various types of metal sheets available, each with its own unique properties and applications. Some common types include stainless steel sheets, aluminium sheets, galvanized steel sheets, and copper sheets.

**Q4.** What are the advantages of using metal sheets?

**Ans:** Metal sheets offer several advantages, such as high strength and durability, resistance to corrosion, versatility in fabrication and shaping, electrical and thermal conductivity (depending on the metal type), and the ability to provide structural support in various applications.

**Q5.** How are metal sheets produced?

**Ans:** Metal sheets are typically produced through a process called rolling, where a large metal ingot or billet is passed through a series of rolling mills to reduce its thickness and increase its length. Additional processes like annealing, pickling, or coating may be applied to enhance the sheet's properties or appearance.

**Q6.** What are some common applications of metal sheets?

**Ans:** Metal sheets find application in a wide range of industries. They are commonly used in construction for roofing, siding, and structural components. They are also used in automotive manufacturing, aerospace, etc.

**Q7.** How are metal sheets measured and sized?

**Ans:** Metal sheets are typically measured and sized based on their dimensions, such as length, width, and thickness. The thickness is often specified in gauge or millimetres, while the length and width can vary depending on the specific requirements of the project or application.

**Q8.** Can metal sheets be formed or shaped?

**Ans:** Yes, metal sheets can be formed or shaped through various processes such as bending, cutting, stamping, or welding. These processes allow metal sheets to be transformed into desired shapes or components for specific applications.

**Q9.** Are metal sheets recyclable?

**Ans:** Yes, metal sheets are highly recyclable. Metals such as steel, aluminium, and copper are commonly recycled, and metal sheet scraps or discarded sheets can be collected and processed for reuse in the production of new metal products.

## WORKSHOP PRACTICES (MEE-101P)

---

**Q10.** What precautions should be taken when working with metal sheets?

**Ans:** When working with metal sheets, it is important to take safety precautions such as wearing appropriate protective gear (gloves, eye protection, etc.), using proper tools and equipment, and following recommended procedures for cutting, bending, or welding to minimize the risk of injury



### LAB EXPERIMENT 5

#### **OBJECTIVE**

To prepare joints for welding suitable for butt welding and lap welding.

#### **TOOLS REQUIRED**

Scale, scribe, hand hack saw, flat file, swing scale protector, welding machine, eye shield, gloves, wire brush, chipping hammer, welding rod.

#### **MATERIAL REQUIRED**

Mild steel plate of 8mm thickness.

#### **PROCEDURE FOR MAKING BUTT JOINT**

1. Two pieces are cut to size and surfaces are cleaned.
2. One edge of both the pieces is prepared at 45 degree angle for making V-groove using file.
3. Electrode is held in electrode holder and earth clamp is clamped to the workpiece.
4. Pieces are positioned properly butting each other and tack weld is done at two end points.
5. 2-3 mm spark gap is maintained and continuous welding is done slowly.
6. Slag is removed using chipping hammer and the weld is cleaned using wire brush.

#### **PROCEDURE FOR MAKING LAP JOINT**

1. Two pieces are cut to size and surfaces to be welded are cleaned properly.
2. Electrode is held in electrode holder and earth clamp is clamped to the workpiece.
3. The pieces are positioned overlapping each other for lap joint and tack weld is done at two end points.
4. 2-3 mm spark gap is maintained and welding is done smoothly.
5. Slag is removed using chipping hammer and weld is cleaned using wire brush.

#### **PRECAUTIONS**

1. Wear apron, shoes, nose mask, gloves and tight fitted clothes.
2. Be careful and attentive while working on welding job.
3. During welding don't see the welding light rays directly without the goggles / face shield.
4. Do not cool the welding piece in water.
5. Do not keep electrode holder on the welding machine.
6. No inflammable material should be present in welding shop.

## WORKSHOP PRACTICES (MEE-101P)

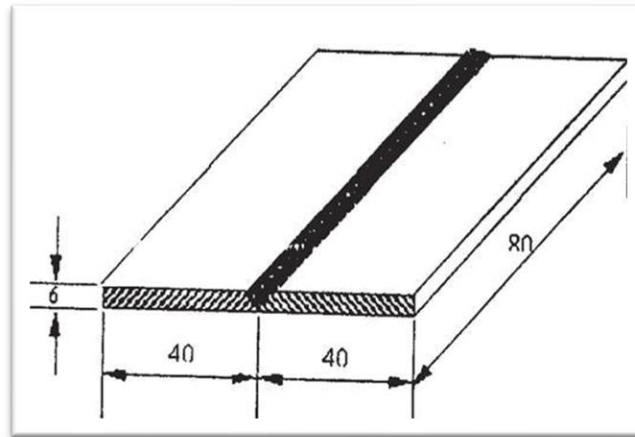

Fig: V Butt Joint

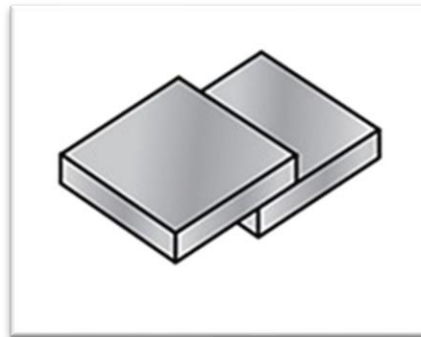

Fig: Lap Joint

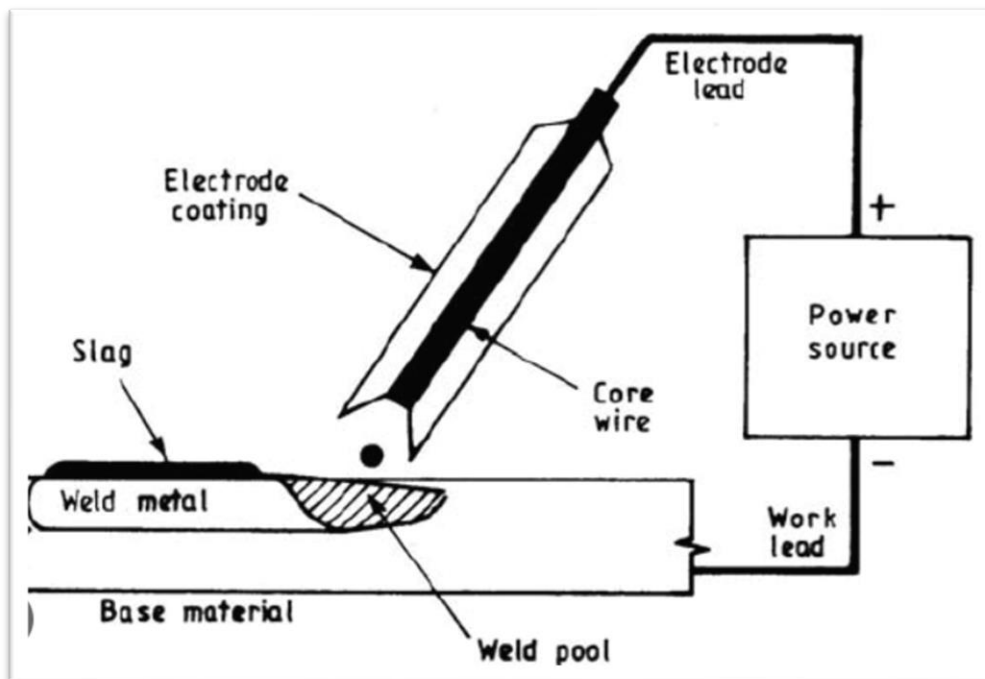

Fig: Arc Welding Machine

## WORKSHOP PRACTICES (MEE-101P)

---

### QUIZ QUESTIONS WITH ANSWERS:

**Q1.** What is welding?

**Ans:** Welding is a fabrication process that involves joining two or more pieces of metal together by melting the edges and allowing them to fuse together. It is commonly used to create strong and permanent bonds between metal components.

**Q2.** What are the different types of welding?

**Ans:** There are several types of welding processes, including:

Arc welding (such as shielded metal arc welding - SMAW and gas metal arc welding - GMAW)

Tungsten inert gas welding (TIG welding)

Metal inert gas welding (MIG welding)

Flux-cored arc welding (FCAW)

Submerged arc welding (SAW)

Resistance welding

Laser welding

Electron beam welding

**Q3.** What are the advantages of welding?

**Ans:** Welding offers several advantages, including the ability to create strong and durable joints, high efficiency in joining metals, versatility in working with various metal types and thicknesses, and the ability to automate the process for increased productivity.

**Q4.** What safety precautions should be followed during welding?

**Ans:** Safety precautions during welding include wearing protective clothing (welding helmet, gloves, safety glasses, and flame-resistant clothing), ensuring proper ventilation in the workspace, working in a well-illuminated area, and following specific safety guidelines for the chosen welding process.

**Q5.** What types of metals can be welded?

**Ans:** Various metals can be welded, including steel, stainless steel, aluminum, copper, brass, and titanium. The welding process and techniques may differ depending on the type of metal being welded.

**Q6.** What is the purpose of filler metal in welding?

**Ans:** Filler metal is often used in welding to provide additional material that fuses with the base metals, helping to create a strong joint. It also helps to control the weld pool and compensate for gaps or variations in joint thickness.

**Q7.** What is the role of shielding gas in welding?

**Ans:** Shielding gas is used in certain welding processes, such as MIG and TIG welding, to protect the weld area from atmospheric contamination. It creates a shield around the weld pool, preventing reactions with oxygen and nitrogen that can lead to defects in the weld.

**Q8.** What is the difference between MIG and TIG welding?

**Ans:** MIG (Metal Inert Gas) welding uses a continuously fed wire electrode and a shielding gas to create the weld. TIG (Tungsten Inert Gas) welding uses a non-consumable tungsten electrode and a separate filler metal, if needed. TIG welding allows for greater precision and control, while MIG welding is generally faster and

## WORKSHOP PRACTICES (MEE-101P)

---

more suitable for thicker materials.

**Q9.** What are common applications of welding?

**Ans:** Welding is used in a wide range of applications, including construction, manufacturing, automotive and aerospace industries, shipbuilding, pipeline construction, structural steel fabrication, and repair and maintenance work.

**Q10.** What are some common weld defects?

**Ans:** Common weld defects include porosity (small holes or voids in the weld), cracks, lack of fusion or penetration, undercutting (excessive melting of the base metal near the weld), and excessive spatter (molten metal expelled during the welding process). Proper welding techniques and quality control measures help minimize these defects.

**LAB EXPERIMENT 6**

**OBJECTIVE**

To study various types of carpentry tools and prepare simple types of at least two wooden joints.

**CARPENTRY TOOLS**

Proper use of following carpentry tools should be understood well.

**MEASURING AND MARKING TOOLS**

Steel scale, try square, bevel square, marking gauge.

**CUTTING TOOLS**

Cross cut saw, tenon saw, key hole saw, compass saw, firmer chisel, dove tailchisel, mortise chisel, adze, rasp.

**BORING TOOLS**

Auger, gimlet.

**PLANNING TOOLS**

Wooden jack plane, metal jack plane.

**STRIKING TOOLS**

Claw hammer cross peen hammer and mallet.

**HOLDING AND SUPPORTING TOOLS**

Bench vice, carpentry vice, C-clamp.

**CROSS LAP JOINT**

**MATERIAL REQUIRED**

Two wooden pieces of required dimensions.

**TOOLS REQUIRED**

Steel scale, try square, cross cut saw, rasp, firmer chisel, and hummers.

**PROCEDURE**

1. Two wooden pieces of required size are to be cut.
2. The pieces are squared using jack plane and rasp.
3. Length, width and height for lap joint are marked on both the pieces.
4. One piece is clamped in vice and unwanted material is removed as permarking, using saw, firmer

## WORKSHOP PRACTICES (MEE-101P)

---

chisel and hummer and the piece is finished using rasp file.

5. The process is repeated on the second piece.
6. The piece should be fitted with normal hand pressure.

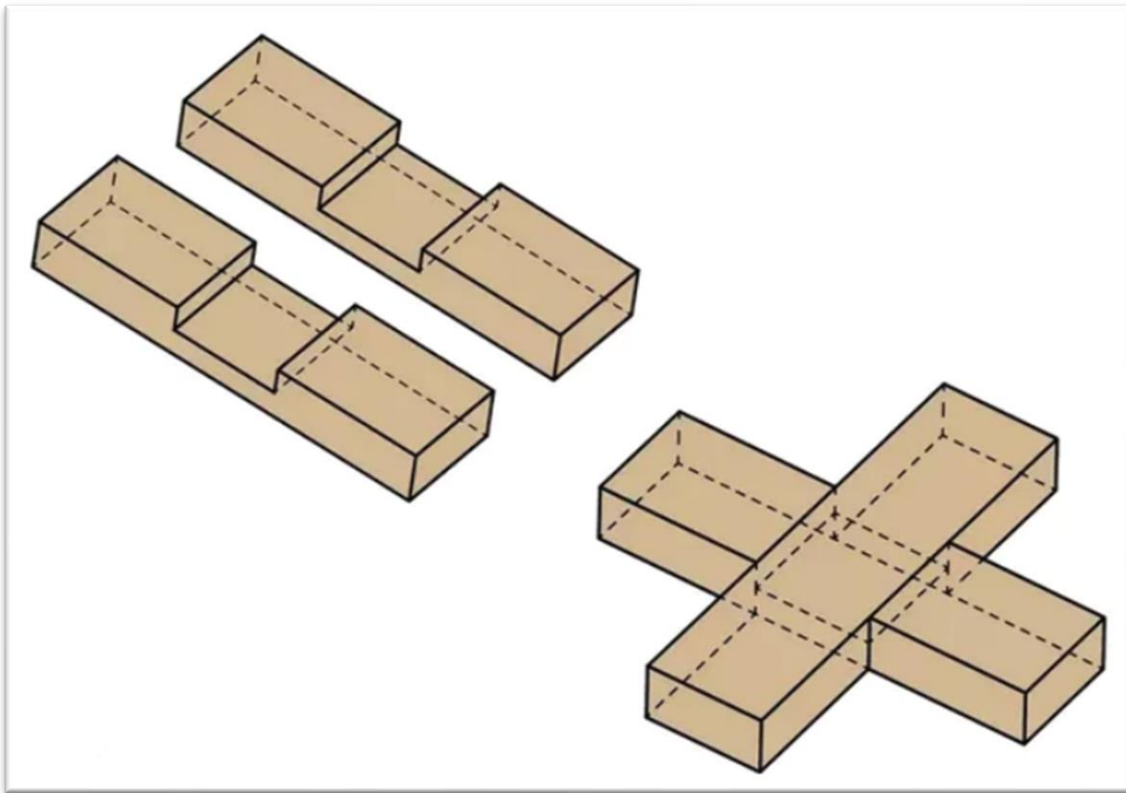

**Fig: Carpentry Job**

### QUIZ QUESTIONS WITH ANSWERS:

**Q1.** What is a hammer?

**Ans:** A hammer is a tool used for driving nails or other fasteners into wood or other materials. It typically consists of a handle and a weighted head that delivers the striking force.

**Q2.** What is a saw?

**Ans:** A saw is a tool with a sharp-edged blade used for cutting wood and other materials. Common types of saws used in carpentry include handsaws, circular saws, and miter saws.

**Q3.** What is a chisel?

**Ans:** A chisel is a cutting tool with a sharp blade used for carving, shaping, or cutting wood. It has a handle and a beveled edge that is struck with a hammer or mallet to remove material.

**Q4.** What is a tape measure?

**Ans:** A tape measure is a flexible measuring tool used to measure lengths and dimensions. It consists of a

## WORKSHOP PRACTICES (MEE-101P)

---

retractable ribbon marked with linear measurements and is commonly used in carpentry for taking accurate measurements.

**Q5.** What is a level?

**Ans:** A level is a tool used to determine whether a surface is horizontal (level) or vertical (plumb). It typically consists of a long, straight body with a bubble or vial filled with liquid and an air bubble that indicates the levelness of the surface.

**Q6.** What is a screwdriver?

**Ans:** A screwdriver is a tool used to tighten or loosen screws. It has a handle and a shaft with a shaped tip that fits into the screw head, allowing for turning or driving screws into wood or other materials.

**Q7.** What is a plane?

**Ans:** A plane is a tool used to smooth and shape wood surfaces. It has a flat base with a cutting blade that shaves off thin layers of wood when pushed or pulled across the surface.

**Q8.** What is a clamp?

**Ans:** A clamp is a device used to hold objects together firmly while they are being worked on or glued. It applies pressure to secure the objects in place until the glue dries or the work is completed.

**Q9.** What is a nail gun?

**Ans:** A nail gun is a power tool used for driving nails into wood or other materials. It uses compressed air or electricity to rapidly shoot nails, making the process of nailing faster and more efficient.

**Q10.** What is a router?

**Ans:** A router is a power tool used in carpentry to hollow out or shape wood. It has a spinning cutting bit that removes material from the workpiece, allowing for decorative edging, grooves, or joinery.

## LAB EXPERIMENT 7

### **OBJECTIVE:**

To study MORTISE/ TENON JOINT

### **MATERIAL REQUIRED**

Two wooden pieces of required dimension

### **TOOLS REQUIRED**

Steel scale, try square, cross cut saw, rasp, firmer chisel, mortiseand tenon chisel and hammers.

### **PROCEDURE**

1. Two wooden pieces of required size are to be cut.
2. The pieces are Squared using jackplane and rasp.
3. One piece is marked for mortise rectangular hole.
4. Another piece is marked for tenon T shape.
5. The mortise hole is made using mortise and dove tail chisel.
6. The tenon T- shape is made using saw.
7. Both the pieces are finished using rasp.
8. Both pieces should be fitted with normal hand pressure.

### **PRECAUTIONS**

1. Wear apron, shoes, gloves and tight fitted clothes.
2. Be careful and attentive while working on carpentry job.
3. Use proper tools for each operation.
4. Don't keep any sharp tool in your pocket.
5. While using chisel cutting should be in direction away from your body.
6. Tools beingused should be well sharpened.

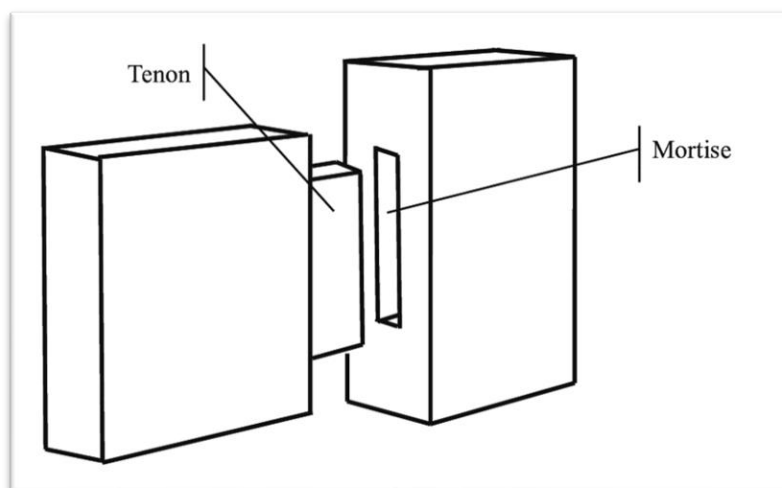

**Fig : Mortise/ Tenon Joint**



## WORKSHOP PRACTICES (MEE-101P)

---

### QUIZ QUESTIONS WITH ANSWERS:

**Q1.** What is a mortise and tenon joint?

**Ans:** A mortise and tenon joint is a traditional woodworking joint used to connect two pieces of wood at a right angle. It consists of a rectangular hole (mortise) in one piece of wood and a corresponding projecting tongue (tenon) on the other piece, which fits into the mortise.

**Q2.** What are the main components of a mortise and tenon joint?

**Ans:** The main components of a mortise and tenon joint are the mortise, which is the cavity or hole, and the tenon, which is the protruding tongue or projection. The tenon is inserted into the mortise, creating a strong and durable connection.

**Q3.** What are the advantages of a mortise and tenon joint?

**Ans:** Mortise and tenon joints are known for their strength, durability, and resistance to shear and pulling forces. They provide a sturdy and reliable connection, making them widely used in woodworking, particularly for furniture, doors, and frames.

**Q4.** What are the different types of mortise and tenon joints?

**Ans:** There are several variations of the mortise and tenon joint, including through mortise and tenon, blind mortise and tenon, wedged mortise and tenon, haunched mortise and tenon, and floating tenon joints. Each variation has its own specific application and structural characteristics.

**Q5.** How is a mortise and tenon joint made?

**Ans:** To create a mortise and tenon joint, a mortise is typically cut into one piece of wood using a chisel or a mortising machine. The tenon is then shaped on the end of the other piece to fit into the mortise. Finally, the tenon is inserted into the mortise and secured with glue, pins, or wedges.

**Q6.** What tools are commonly used to make a mortise and tenon joint?

**Ans:** Common tools used to create a mortise and tenon joint include chisels, mallets, a mortising machine, a tenon saw, and a marking gauge. Power tools such as a router or a table saw can also be used for more precise and efficient cutting.

**Q7.** When is a mortise and tenon joint used?

**Ans:** A mortise and tenon joint is used in various woodworking applications, particularly where strength, durability, and aesthetics are important. It is commonly used in furniture making, cabinet construction, timber framing, and architectural woodworking.

**Q8.** How strong is a mortise and tenon joint?

**Ans:** When properly constructed, a mortise and tenon joint can be incredibly strong and resistant to forces. The large gluing surface area and interlocking nature of the joint contribute to its strength, making it suitable for heavy-duty applications.

## WORKSHOP PRACTICES (MEE-101P)

---

**Q9.** Can a mortise and tenon joint be disassembled?

**Ans:** In most cases, a mortise and tenon joint is designed to be permanent and not easily disassembled. However, in certain situations, such as for repair or restoration purposes, the joint can be carefully disassembled with the use of specialized tools or techniques.

**Q10.** Are there any variations or alternatives to a mortise and tenon joint?

**Ans:** While the mortise and tenon joint is a widely used and versatile joint, there are alternative methods of joining wood, such as dowel joints, biscuit joints, dovetail joints, and pocket hole joints. These joints offer different strengths, aesthetics, and ease of construction depending on the specific application.

### LAB EXPERIMENT 8

#### **OBJECTIVE:**

To prepare simple engineering components/ shapes by forging

#### **MATERIAL REQUIRED**

M.S. rod of diameter 8 mm, for making ring.

M.S. square 16×16 mm for chisel.

#### **TOOLS REQUIRED**

Steele scale, scribe, hand saw, cross cut file, furnace, hammer, anvil, flattong, and swage block.

#### **PROCEDURE FOR CHISEL**

1. M.S. square of required length is to be cut.
2. One end of the piece is heated in furnace to red hot condition.
3. Hot piece is brought to anvil holding by a tong.
4. The piece is shaped using smith hammer.
5. If required the piece is reheated and the process is repeated.
6. The piece is put in to water for tempering.

#### **PROCEDURE FOR RING**

1. M.S rod of required length to be cut.
2. The piece is heated in furnace to red hot conditions.
3. Hot piece is held with a tong and brought to anvil.
4. The piece is shaped on horn anvil using hammer.
5. If required the piece is re heated and the process is repeated.
6. Complete round is made on swage block.
7. The piece is put in to the water for tempering.

#### **PRECAUTIONS**

1. Wear apron, shoes, nose mask, gloves and tight fitted clothes.
2. Be careful and attentive while working on job of forging.
3. Hammering should be done only when the work piece is hot.
4. Always use appropriate tongs and tools.

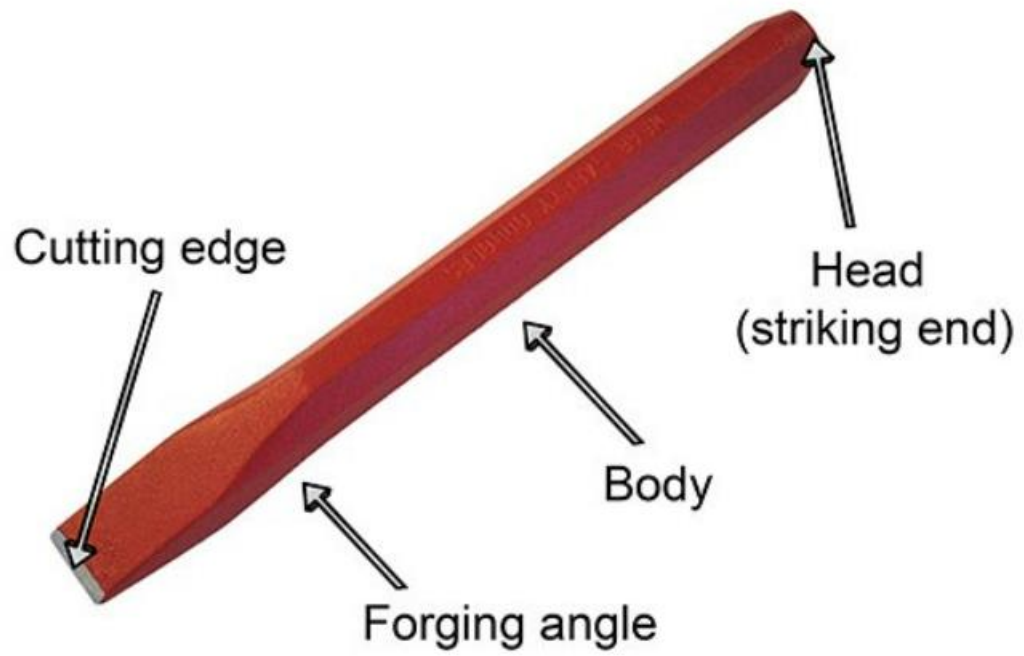

Fig: Chisel

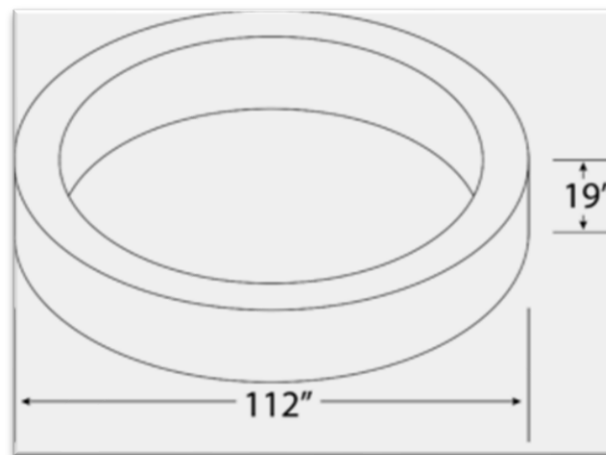

Fig: Ring

## WORKSHOP PRACTICES (MEE-101P)

---

### QUIZ QUESTIONS WITH ANSWERS:

**Q1.** What is forging?

**Ans:** Forging is a manufacturing process that involves shaping metal by applying compressive forces through the use of a hammer or press. It is commonly used to create components with increased strength and durability.

**Q2.** What are some simple engineering components or shapes that can be made by forging?

**Ans:** Some simple engineering components or shapes that can be made by forging include:

Bolts and fasteners

Hand tools like wrenches and hammers

Flanges and fittings

Shafts and axles

Gears and sprockets

Connecting rods

Valve bodies

Hooks and eye bolts

**Q3.** How is forging used to create these components?

**Ans:** During forging, the metal is heated to a specific temperature to make it malleable. It is then placed on an anvil or die and struck with a hammer or pressed using a hydraulic or mechanical press. The repeated blows or pressure reshape the metal into the desired component or shape.

**Q4.** What are the advantages of forging for creating engineering components?

**Ans:** Forging offers several advantages for creating engineering components, including:

Enhanced strength and durability due to the grain flow and improved metallurgical properties.

Improved mechanical properties, such as resistance to fatigue and impact.

The ability to achieve complex shapes and precise dimensions.

Consistency and reliability in component quality.

Cost-effectiveness for high-volume production.

**Q5.** What types of materials are commonly used in forging?

**Ans:** A variety of materials can be forged, including ferrous metals (such as steel and iron) and non-ferrous metals (such as aluminium, copper, and titanium). The specific material selection depends on the desired properties and requirements of the component.

**Q6.** Are there different forging methods for creating components?

**Ans:** Yes, there are different forging methods used to create components. The most common methods include:

Open-die forging: The metal is shaped between flat dies or on an open anvil.

Closed-die forging: The metal is shaped within closed dies that contain specific impressions and shapes.

Upset forging: The metal is compressed and shaped by localized upsetting, often used for creating heads on bolts or rivets.

Drop forging: A mechanical or gravity drop hammer strikes the metal to shape it.

Press forging: Hydraulic or mechanical presses apply steady pressure to shape the metal

## WORKSHOP PRACTICES (MEE-101P)

---

**Q7.** What post-forging processes are commonly applied to components?

**Ans:** After forging, components may undergo additional processes to achieve the desired final properties or appearance. These processes can include heat treatment, machining, surface finishing (such as grinding or polishing), and inspection to ensure quality.

**Q8.** Can complex shapes be forged?

**Ans:** Yes, forging can be used to create complex shapes. While simple shapes are more common, forging techniques like impression die forging and precision forging can be employed to produce intricate and near-net-shape components with tight tolerances.

**Q9.** What are the limitations of forging?

**Ans:** Forging does have some limitations, including the need for specialized equipment and skilled labor. It may not be suitable for all types of shapes or materials, and certain intricate designs may require additional machining or finishing operations after forging.

**Q10.** What industries commonly utilize forged components?

**Ans:** Forged components are widely used in industries such as automotive, aerospace, oil and gas, construction, and heavy machinery. These industries rely on forged components due to their strength, durability, and performance characteristics.

# WORKSHOP PRACTICES (MEE-101P)

---

## LAB EXPERIMENT 9

### OBJECTIVE

To prepare mold and core assembly, to put metal in the mold and fettle the casting.

### MATERIAL REQUIRED

Green sand mould

River sand	-	70%
Clay sand	-	10%
Molasses	-	5%
Water	-	8-10%
Additives		
Coal dust	-	2-5%
Saw dust	-	2%
Silica sand	-	2%

### TOOLS REQUIRED

Moulding flask (cope and drag), shovel, hand riddle, vent wire, trowel, lifter, gate cutter, strike off bar, runner and riser, sprue pin, slicks, rammer, swab, crucible furnace, tong.

### PROCEDURE

1. A mould box suitable for the pattern should be selected.
2. Lower part of the pattern is placed in the middle of drag.
3. Drag is filled with the moulding sand and rammed properly.
4. Parting sand is sprinkled over the top surface of the mould.
5. The cope is placed over the drag in proper position.
6. Then the top part of the drag in proper position.
7. Runner and riser are placed in position and the cope is filled with sand and rammed.
8. Then the cope is separated from drag and the pattern is removed.
9. The gate is made using gate cutter and the mold cavity is repaired for small damage.
10. The core is placed in position and located.
11. The mould is allowed drying.
12. The mould is ready for pouring.
13. Metal is melted in crucible to correct temperature.
14. The crucible is held with a tong and the metal is poured in the mould and allowed to solidify and cool.
15. After cooling the casting is extracted breaking the mould.
16. Gates and riser are cut off.
17. The entire surface is cleaned using wire brush.

## WORKSHOP PRACTICES (MEE-101P)

---

### PRECAUTIONS

1. Wear apron, shoes, gloves and tight fitted clothes.
2. Be careful and attentive while working on hot metal.
3. Runner and riser should be placed at the right place.
4. Sand should be mixed properly.

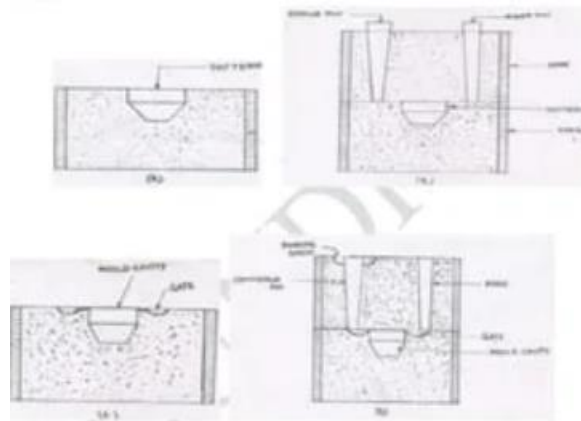

**Fig: Moulding**

### QUIZ WITH ANSWERS

**Q1.** What is a mold?

**Ans:** A mold is a hollow container or cavity that is used to shape and form a material, typically a liquid or molten substance, into a desired solid shape. It is typically made of a material such as metal, plastic, or sand.

**Q2.** What is the purpose of a mold?

**Ans:** The purpose of a mold is to provide a defined shape or form to a material during the manufacturing or casting process. It helps in reproducing the desired shape accurately and consistently.

**Q3.** What are the common types of molds?

**Ans:** Common types of molds include:

Injection molds: Used in plastic injection molding processes.

Die-casting molds: Used in metal casting processes, where molten metal is injected into the mold.

Sand molds: Used in sand casting processes, where a mixture of sand and a binding agent is shaped around a pattern to form the mold.

Rubber molds: Used in rubber or silicone casting processes to create flexible molds for casting various materials.



## WORKSHOP PRACTICES (MEE-101P)

---

**Q4.** What is a core?

**Ans:** A core is a solid, typically removable, object placed within a mold to create hollow or internal features in a cast component. It is often made of sand, metal, or other refractory materials.

**Q5.** What is the purpose of a core in casting?

**Ans:** The purpose of a core is to create voids or cavities within a cast component where solid material cannot be reached through the mold alone. Cores are used to form features such as internal passages, holes, or intricate shapes that cannot be achieved using the mold alone.

**Q6.** What are the common types of cores?

**Ans:** Common types of cores include:

Sand cores: Made of sand mixed with binders, they are commonly used in sand casting processes.

Shell cores: Created using a mixture of sand and a thermosetting resin, they are used in shell molding processes.

Ceramic cores: Made from ceramic materials, they are used in investment casting processes to create intricate internal features.

**Q7.** How are molds and cores made?

**Ans:** Molds and cores are made through various processes such as pattern making, mold or core assembly, and mold or core casting. Depending on the casting process, materials like sand, wax, metal, or resin are used to create the mold or core.

**Q8.** Can molds and cores be reused?

**Ans:** Yes, molds and cores can be reused, depending on the casting process and the materials used. Some molds or cores are designed for multiple uses, while others may need to be broken or destroyed to remove the cast component, rendering them unusable for further casting.

**Q9.** What industries use molds and cores?

**Ans:** Molds and cores are used in various industries, including automotive, aerospace, foundries, construction, and manufacturing. They are particularly common in metal casting processes for producing components with complex shapes or internal features.

**Q10.** What is the importance of mold and core design?

**Ans:** Mold and core design plays a crucial role in the success of the casting process. Proper design ensures the accurate reproduction of the desired shape, adequate cooling and solidification of the material, and the ability to remove the cast component without damage or distortion.

## WORKSHOP PRACTICES (MEE-101P)

---

### LAB EXPERIMENT 10

#### **OBJECTIVE**

To prepare horizontal surface/ vertical surface/ curved surface/ slots or V-grooves on a shaper/planner.

#### **TOOL REQUIRED**

Tool holder, shaping tool, center punch, hammer.

#### **MATERIAL REQUIRED**

Mild steel work piece.

#### **INSTRUMENT REQUIRED**

Steel rule, vernier caliper, vernier height gauge, depth gauge, try square

#### **PROCEDURE**

1. Work piece of required dimension to be cut on power hack saw.
2. The job is fixed in vice of shaper machine.
3. Top surface is machined first.
4. The Job surface is inverted and clamped tightly in the vice.
5. All the remaining surfaces are machined in sequence.
6. Then marking is done as per the drawing for making groove.
7. The groove is machined using round nose cutting tool.
8. For making the groove feed to the table and tool is given simultaneously.
9. The groove is shaped in different cuts to achieve the desired depth.

#### **PRECAUTIONS**

1. Work piece should be firmly gripped in the vice.
2. Adjust the stock length as per job.
3. Do not over speed or over cut the machine during operation.
4. Handgloves apron and shoes must be used while working.

## WORKSHOP PRACTICES (MEE-101P)

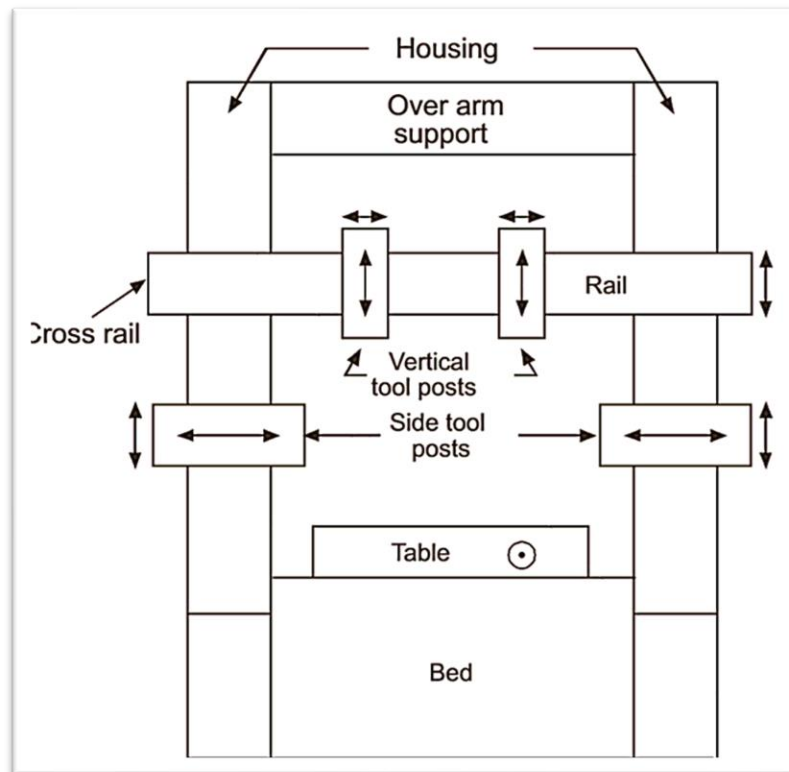

**Fig: Planner Machine**

### QUIZ WITH ANSWERS

**Q1.** What is a horizontal surface?

**Ans:** A horizontal surface refers to a flat surface that is parallel to the horizon or ground level. It is perpendicular to the vertical axis and typically lies parallel to the working surface or reference plane.

**Q2.** What is a vertical surface?

**Ans:** A vertical surface refers to a flat surface that is perpendicular to the ground or horizontal plane. It is oriented upright and stands at a 90-degree angle to the horizontal surface.

**Q3.** What is a curved surface?

**Ans:** A curved surface refers to a three-dimensional surface that is not flat or straight. It has a continuously changing curvature and can be concave or convex in shape.

**Q4.** What are slots or V-grooves on a shaper or planer?

**Ans:** Slots or V-grooves on a shaper or planer are cuts or recesses made on a workpiece using the shaping or planning machine. They can be straight slots or V-shaped grooves, typically used for specific purposes such as guiding a part or creating precise fits for mating components.

## WORKSHOP PRACTICES (MEE-101P)

---

**Q5.** What is a shaper?

**Ans:** A shaper is a machine tool used to machine flat surfaces on a workpiece. It utilizes a single-point cutting tool that moves in a linear motion, controlled by the machine, to shape the workpiece.

**Q6.** What is a planer?

**Ans:** A planer is a machine tool used to create flat surfaces or remove material from the surface of a workpiece. It uses a cutting tool that moves in a reciprocating motion, typically in a horizontal direction, to achieve the desired result.

**Q7.** What are the applications of horizontal surfaces?

**Ans:** Horizontal surfaces have various applications, such as providing stable working platforms, supporting structures, tables, floors, and flat workpiece mounting surfaces.

**Q8.** What are the applications of vertical surfaces?

**Ans:** Vertical surfaces have diverse applications, including walls, panels, pillars, upright supports, and partitions. They are commonly used in construction, interior design, and architectural elements.

**Q9.** What are the applications of curved surfaces?

**Ans:** Curved surfaces find applications in a wide range of industries and products, such as automobile bodies, aircraft wings, bowls, cylindrical pipes, sculptures, and furniture design. They offer aesthetic appeal, structural strength, and aerodynamic advantages.

**Q10.** What are the applications of slots or V-grooves on a shaper or planer?

**Ans:** Slots or V-grooves on a shaper or planer have various applications, including creating keyways, guiding parts or components, providing alignment features, facilitating sliding or mating surfaces, and enhancing the functionality or assembly of mechanical systems.

## WORKSHOP PRACTICES (MEE-101P)

---

This lab manual has been updated by

Prof. Rajesh Mattoo  
([rajesh.mattoo@ggnindia.dronacharya.info](mailto:rajesh.mattoo@ggnindia.dronacharya.info))

Crosschecked By  
HOD Applied Sciences and Humanities

Please spare some time to provide your valuable feedback.