



LABORATORY MANUAL

B.Tech. Semester- VI

HEAT TRANSFER

Subject code: LC-ME-314G

Prepared by:

Mr. Ankit Agarwal

Checked by:

Mrs. Neha Chauhan

Approved by:

Name : Prof. (Dr.) Isha Malhotra

Sign.:

Sign.:

Sign.:

**DEPARTMENT OF MECHANICAL ENGINEERING
DRONACHARYA COLLEGE OF ENGINEERING
KHENTAWAS, FARRUKH NAGAR, GURUGRAM (HARYANA)**

Table of Contents

1. Vision and Mission of the Institute
2. Vision and Mission of the Department
3. Programme Educational Objectives (PEOs)
4. Programme Outcomes (POs)
5. Programme Specific Outcomes (PSOs)
6. University Syllabus
7. Course Outcomes (COs)
8. CO- PO and CO-PSO mapping
9. Course Overview
10. List of Experiments
11. DOs and DON'Ts
12. General Safety Precautions
13. Guidelines for students for report preparation
14. Lab assessment criteria
15. Details of Conducted Experiments
16. Lab Experiments

Vision and Mission of the Institute

Vision:

“To impart Quality Education, to give an enviable growth to seekers of learning, to groom them as World Class Engineers and Managers competent to match the expanding expectations of the Corporate World has been our ever enlarging vision extending to new horizons since the inception of Dronacharya College of Engineering.”

Mission:

1. To prepare students for full and ethical participation in a diverse society and encourage lifelong learning by following the principle of ‘Shiksha evam Sahayata’ i.e. Education & Help.
2. To impart high-quality education, knowledge and technology through rigorous academic programs, cutting-edge research, & Industry collaborations, with a focus on producing engineers & managers who are socially responsible, globally aware, & equipped to address complex challenges.
3. Educate students in the best practices of the field as well as integrate the latest research into the academics.
4. Provide quality learning experiences through effective classroom practices, innovative teaching practices and opportunities for meaningful interactions between students and faculty.
5. To devise and implement programmes of education in technology that are relevant to the changing needs of society, in terms of breadth of diversity and depth of specialization.

Vision and Mission of the Mechanical Department

Vision:

“To become a Centre of Excellence in teaching and research in the field of Mechanical Engineering for producing skilled professionals having a zeal to serve society.”

Mission:

M1: To create an environment where students can be equipped with strong fundamental concepts, various experiments and problem solving skills.

M2: To provide an exposure to emerging technologies by providing hands on experience for generating competent professionals.

M3: To promote Research and Development in the frontier areas of Mechanical Engineering and encourage students for pursuing higher education.

M4: To inculcate in students ethics, professional values, team work and leadership skills.

Programme Educational Objectives (PEOs)

PEO 1: Engineers will practice the profession of engineering using a systems perspective and analyze, design, develop, optimize & implement engineering solutions and work productively as engineers, including supportive and leadership roles on multidisciplinary teams.

PEO 2: Continue their education in leading graduate programs in engineering & interdisciplinary areas to emerge as researchers, experts, educators & entrepreneurs and recognize the need for, and an ability to engage in continuing professional development and life-long learning.

PEO 3: Engineers, guided by the principles of sustainable development and global interconnectedness, will understand how engineering projects affect society and the environment.

PEO 4: Promote Design, Research, and implementation of products and services in the field of Engineering through Strong Communication and Entrepreneurial Skills.

PEO 5: Re-learn and innovate in ever-changing global economic and technological environments of the 21st century.

Heat Transfer Lab (LC –ME-314G)

Programme Outcomes (POs)

Over completion of the Course our graduates will have ability to

1. Apply knowledge of computing, mathematical foundations, algorithmic principles, and engineering theory in the modeling and design of systems to real-world problems (fundamental engineering analysis skills).
2. Apply and integrate knowledge and understanding of other engineering disciplines to support study of their own engineering discipline.
3. Design and conduct experiments, as well as to analyze and interpret data (information retrieval skills). Practical application of engineering skills, combining theory and experience, and use of other relevant knowledge and skills.
4. Analyze a problem, identify, formulate and use the appropriate computing and engineering requirements for obtaining its solution(engineering problem solving skills).
5. Understand the appropriate codes of practice and industry standards.
6. Identify, classify and describe the performance of systems and components through the use of analytical methods and modeling techniques.
7. Investigate and define a problem and identify constraints including environmental and sustainability limitations, health and safety and risk assessment issues.
8. Communicate effectively, both in writing and orally (speaking / writing skills).
9. Understand professional, ethical, legal, security and social issues and responsibilities (professional integrity).
10. Understand customer and user needs and the importance of considerations such as Aesthetics.
11. Use creativity to establish innovative solutions.
12. Adapt to a rapidly changing environment by having learned and applied new skills and new technologies.
13. To Significantly contribute to delivery of desired component, product, or process.
14. Formulate and solve moderately complex engineering problems, accounting for hardware/software/human interactions.
15. Recognize the importance of professional development by pursuing postgraduate studies or face competitive examinations that offer challenging and rewarding careers in computing.
16. Apply the Knowledge of management techniques which may be used to achieve engineering Objectives within that context.

Program Specific Outcomes (PSOs)

On successful completion of the Mechanical Engineering Degree programme, the Graduates shall exhibit the following:

PSO1: Apply the knowledge gained in Mechanical Engineering for design and development and manufacture of engineering systems.

PSO2: Apply the knowledge acquired to investigate research-oriented problems in mechanical engineering with due consideration for environmental and social impacts

PSO3: Use the engineering analysis and data management tools for effective management of multidisciplinary projects.

University Syllabus

1. To determine the thermal conductivity of a metallic rod.
2. To determine the thermal conductivity of an insulating power.
3. Measurement of heat transfer rate in a channel flow using winglets.
4. To determine the thermal conductivity of a solid by the guarded hot plate method.
5. To find the effectiveness of a pin fin in a rectangular duct natural convective condition and plot temperature distribution along its length.
6. To find the effectiveness of a pin fin in a rectangular duct under forced convective and plot temperature distribution along its length.
7. To determine the surface heat transfer coefficient for a heated vertical tube under natural convection and plot the variation of local heat transfer coefficient along the length of the tube. Also compare the results with those of the correlation.
8. To determine average heat transfer coefficient for a externally heated horizontal pipe under forced convection & plot Reynolds and Nusselt numbers along the length of pipe. Also compare the results with those of the correlations.
9. To measure the emmissivity of the gray body (plate) at different temperature and plot the variation of emmissivity with surface temperature.
10. To find overall heat transfer coefficient and effectiveness of a heat exchange under parallel and counter flow conditions. Also plot the temperature distribution in both the cases along the length of heat of heat exchanger.
11. To verify the Stefan-Boltzmann constant for thermal radiation.
12. To demonstrate the super thermal conducting heat pipe and compare its working with that of the best conductor i.e. copper pipe. Also plot temperature variation along the length with time or three pipes.
13. To study the two phases heat transfer unit.
14. To determine the water side overall heat transfer coefficient on a cross-flow heat exchanger.
15. Design of Heat exchanger using CAD and verification using thermal analysis package eg. Ideas etc.

NOTE: At least ten experiments are to be performed in the Semester.

Heat Transfer Lab (LC –ME-314G)

Course Outcomes (COs)

Upon successful completion of the course, the students will be able to:

CO314.1: Understand the basic concept of conduction, convection and radiation heat transfer.

CO314.2: Formulation of one dimension conduction problems

CO314.3: Application of empirical correlations for both forced and free convection for determines the value of convection heat transfer coefficient.

CO314.4: Expedite basic concept of the radiation heat transfer for black and grey body.

CO314.5: Learning of thermal analysis and sizing of Heat exchangers.

CO-PO Mapping

COs/POs	PO1	PO2	PO3	PO4	PO5	PO6	PO7	PO8	PO9	PO10	PO11	PO12	PO13	PO14	PO15	PO16
CO314.1	3	3	3	-	2	-	3	3	3	2	-	3	3	-	-	3
CO314.2	-	3	-	-	2	3	-	-	-	2	-	3	-	-	2	3
CO314.3	-	-	3	3	-	3	-	-	3	-	3	-	3	3	-	-
CO314.4	3	-	3	-	2	-	3	3	-	2	-	3	-	3	2	3
CO314.5	3	3	-	3	-	3	-	-	3	2	3	-	3	3	-	3

CO-PSO Mapping

	PSO1	PSO2	PSO3
CO314.1	3	2	-
CO314.2	2	3	-
CO314.3	3	2	-
CO314.4	3	2	3
CO314.5	2	3	3

Course Overview

Heat transfer occurs in many unit operations in variety of processes in chemical, petrochemical, power and pharmaceutical industries. Understanding the fundamentals governing heat transfer is key to designing equipment that involves heat exchange. This course for undergraduate students covers the fundamental aspects and quantitation of different modes of heat transport. This course deals with both the fundamental and applied aspects, starting with the basic concepts and governing equations and evolving into the design of relevant industrial units. The students will be made aware of the core scientific issues and will be encouraged to solve problems on their own.

List of Experiments

S. No.	NAME OF EXPERIMENTS	Course Outcomes
1.	To determine the thermal conductivity of a metallic rod.	CO314.1
2.	To determine the thermal conductivity of an insulating power.	CO314.1, CO314.2
3.	To determine the thermal conductivity of a solid by the guarded hot plate method.	CO314.1, CO314.3
4.	To find the effectiveness of a pin fin in a rectangular duct natural convective condition and plot temperature distribution along its length.	CO314.2
5.	To find the effectiveness of a pin fin in a rectangular duct under forced convective and plot temperature distribution along its length.	CO314.2, CO314.3
6.	To determine the surface heat transfer coefficient for a heated vertical tube under natural convection and plot the variation of local heat transfer coefficient along the length of the tube. Also compare the results with those of the correlation.	CO314.2, CO314.3
7.	To determine average heat transfer coefficient for a externally heated horizontal pipe under forced convection & plot Reynolds and Nusselt numbers along the length of pipe. Also compare the results with those of the correlations.	CO314.2, CO314.3, CO314.5
8.	To measure the emissivity of the gray body (plate) at different temperature and plot the variation of emissivity with surface temperature.	CO314.4
9.	To find overall heat transfer coefficient and effectiveness of a heat exchange under parallel and counter flow conditions. Also plot the temperature distribution in both the cases along the length of heat of heat exchanger.	CO314.3, CO314.5
10.	To verify the Stefan-Boltzmann constant for thermal radiation.	CO314.4

DOs and DON'Ts

Heat Transfer Lab (LC –ME-314G)

DOs

1. Work deliberately and carefully.
2. Keep your work area clean.
3. Students must wear college uniform and carry their college ID.
4. Students should have separate note book for practical.
5. Students should have their own pencil, eraser, scale, along with pen and lab note book.
6. Handle the equipment /models carefully.

DON'Ts

1. Do not wander around the room, distract other students, startle other students or interfere with the laboratory experiments of others.
2. Do not eat food, drink beverages or chew gum in the laboratory.
3. Do not open any irrelevant internet sites on lab computer.

General Safety Precautions

Precautions (In case of Injury or Electric Shock)

1. To break the victim with live electric source, use an insulator such as fire wood or plastic to break the contact. Do not touch the victim with bare hands to avoid the risk of electrifying yourself.
2. Unplug the risk of faulty equipment. If main circuit breaker is accessible, turn the circuit off.
3. If the victim is unconscious, start resuscitation immediately, use your hands to press the chest in and out to continue breathing function. Use mouth-to-mouth resuscitation if necessary.
4. Immediately call medical emergency and security. Remember! Time is critical; be best.

Precautions (In case of Fire)

1. Turn the equipment off. If power switch is not immediately accessible, take plug off.
2. If fire continues, try to curb the fire, if possible, by using the fire extinguisher or by covering it with a heavy cloth, if possible, isolate the burning equipment from the other surrounding equipment.
3. Sound the fire alarm by activating the nearest alarm switch located in the hallway.

Emergency: Reception

Security: Main Gate

Lab assessment criteria

Heat Transfer Lab (LC –ME-314G)

An estimated 10 lab classes are conducted in a semester for each lab course. These lab classes are assessed continuously.

Each lab experiment is evaluated based on 5 assessment criteria as shown in following table. Assessed performance in each experiment is used to compute CO attainment as well as internal marks in the lab course.

Grading Criteria	Exemplary (4)	Competent (3)	Needs Improvement (2)	Poor (1)
AC1: Pre-Lab written work (this may be assessed through viva)	Complete procedure with underlined concept is properly written	Underlined concepts written but procedure is incomplete	Not able to write concept and procedure	Underlined concepts not clearly understood
AC2: Program Writing/ Modeling	Assigned problem is properly analyzed, correct solution designed, appropriate language constructs/ tools are applied.	Assigned problem is properly analyzed, correct solution designed, appropriate language constructs/ tools are applied	Assigned problem is properly analyzed & correct solution designed	Assigned problem is improperly analyzed
AC3: Identification & Removal of errors/ bugs	Program/solution written is readable Able to identify errors/ bugs and remove them	Able to identify errors/ bugs and remove them with little bit of guidance	Is dependent totally on someone for identification of errors/ bugs and their removal	Unable to understand the reason for errors/ bugs even after they are explicitly pointed out Solution is not well demonstrated and implemented concept is not clearly explained
AC4: Execution & demonstration	All variants of input /output are tested, Solution is well demonstrated and implemented concept is clearly explained	All variants of input /output are not tested, However, solution is well demonstrated and implemented concept is clearly explained	Only few variants of input /output are tested, Solution is well demonstrated but implemented concept is not clearly explained	Less than 40 % of the assigned problems are well recorded with objective, design contracts and solution along with
AC5: Lab Record Assessment	All assigned problems are well recorded with objective, design constructs and solution along with Performance analysis using all variants of input and output	More than 70 % of the assigned problems are well recorded with objective, design constructs and solution along with Performance analysis is done with all variants of input and output	Less than 70 % of the assigned problems are well recorded with objective, design contracts and solution along Performance analysis is done with all variants of input and output	Performance analysis is done with all variants of input and output

Guidelines to students for report preparation

All students are required to maintain a record of the experiments conducted by them. Guidelines for its preparation are as follows:

- 1) All files must contain a title page followed by an index page. The files will not be signed by the faculty without an entry in the index page.

- 2) Student's Name, Roll number and date of conduction of experiment must be written on all pages.

- 3) For each experiment, the record must contain the following
 - (i) Aim/Objective of the experiment
 - (ii) Pre-experiment work (as given by the faculty)
 - (iii) Lab assignment questions and their solutions
 - (iv) Test Cases (if applicable to the course)
 - (v) Results/ output

Note:

1. Students must bring their lab record along with them whenever they come for the lab.
2. Students must ensure that their lab record is regularly evaluated.

Experiment No. -1

Aim:- To determine thermal conductivity of metal rod.

INTRODUCTION:

Thermal conductivity is the physical property of the material denoting the ease with which a particular substance can accomplish the transmission of thermal energy by molecular motion. Thermal conductivity of a material is found to depend on the chemical composition of the substance or substances of which it is composed, the phase (i.e. gas, liquid or solid) in which it exists, its crystalline structure if a solid, the temperature and pressure to which it is subjected, and whether or not it is a homogeneous material.

Table 1 – Lists the values of thermal conductivity of some common metal:

SOLID'S (Metal)	Thermal Conductivity W/m °C	State
Pure Copper	380	20 degree
Brass	110	- - do - -
Steel (0.5%C)	54	- - do - -
S. S.	17	- - do - -

Mechanism of Thermal Energy Conduction in Metals:

Thermal energy may be conducted in solids by two modes:

1. Lattice Vibration.
2. Transport by free electrons.

Thermal energy can be conducted in solids by free electrons and by lattice vibrations. Large numbers of free electrons move about in the lattice structure of the material in good conductors. These electrons carry thermal energy from higher temperature region to lower temperature region in a similar way they transport electric charge. In fact, these electrons are frequently referred as electron gas. Energy may also be transferred as vibrational energy in the lattice structure of the material. In general, however, this mode of energy transfer is not as large as electron transport and hence, good electrical conductors are always good heat conductors, e.g. copper, silver etc.

However, with increase in temperature, lattice vibrations come in the way of transport by free electrons and for most the metals thermal conductivity decreases with increase in temperature. It is for this reason that good electrical conductors are almost always good heat conductor viz. Copper, Aluminium and silver. With increase in the temperature,

however the increased lattice vibrations come in the way of the transport by free electrons for most of the pure metals the thermal conductivity decreases with increase in the temperature.

Heat Transfer Lab (LC –ME-314G)

APPARATUS:

The experimental set up consists of the metal bar, one end of which is heated by an electric heater while the other end of the bar projects inside the cooling water jacket. The middle portion of the bar is surrounded by a cylindrical shell filled with the asbestos insulating powder. The temperature of the bar is measured at eight different sections while the radial temperature distribution is measured by separate thermocouples at two different sections in the insulating shell.

The heater is provided with a dimmer stat for controlling the heat input. Water under constant heat condition is circulated through the jacket and its flow rate and temperature rise are noted.

SPECIFICATION:

- Metal bar – Copper, 25 mm O.D., approx. 430 mm long with insulation shell along the length and water cooled heat sink at the other end.
- Test length of the bar – 240 mm.
- Thermocouples – Chromel /alumel, 10 nos.
- Band Nichrome heater to heat the bar.
- Dimmerstat to control the heat input – 2A, 230 V.
- Voltmeter and Ammeter to measure the heater input.
- Multichannel Digital temperature indicator, 0.1°C least count, 0-200°C with channel selector switch.
- Measuring flask to measure water flow.

EXPERIMENTAL PROCEDURE:

- Start the electric supply.
- Start heating the bar by adjusting the heater input to, say, 80 volts or 100 volts.
- Start cooling water supply through the heat sink and adjust it around 350-400 cc per minute.
- Bar temperature will start rising. Go on checking the temperature at time intervals of 5 minutes.
- When all the temperatures remain steady, note down all the observations and complete the observation table.

OBSERVATION TABLE:

Heat Transfer Lab (LC –ME-314G)

Sr. No.	Test Bar Temperature °C								Shell Temperature °C		Water Temperature °C		Water Flow Rate Litr/Sec.
	T ₁	T ₂	T ₃	T ₄	T ₅	T ₆	T ₇	T ₈	T ₉	T ₁₀	T ₁₁	T ₁₂	

Using the temperatures of the bar at various points, plot the temperature distribution along the length of the bar and determine the slopes of the graph (i.e. temperature drop per unit length) dT/dx at the sections AA, BB, CC as shown in figure.

(Note : As the value of temperature goes on decreasing along the length of the bar, the value of slope dT/dx is negative.)

Heat is flowing through the bar from heater end to water heat sink. When steady state is reached, heat passing through the section CC of the bar is heat taken by water.



Schematic Diagram:

Heat Transfer Lab (LC –ME-314G)

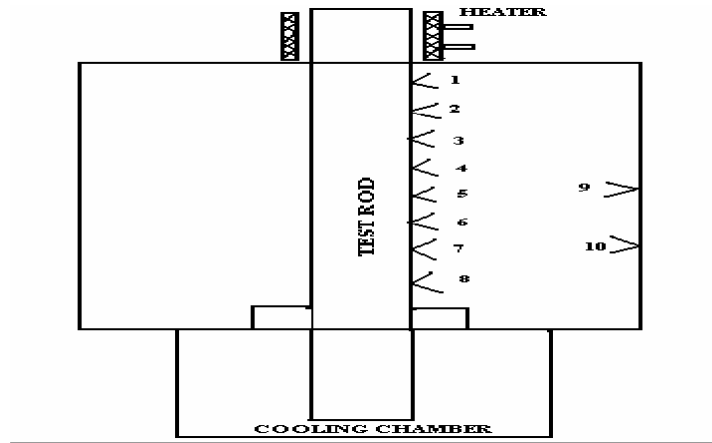

1) Heat passing through section CC

$$Q_{cc} = m \cdot C_p \cdot \Delta T \text{ watts}$$

Where ,

m = mass flow rate of cooling water, Kg/s

C_p = specific heat of water

$$= 4180 \text{ J/Kg } ^\circ\text{C}$$

ΔT = (Water outlet temperature) – (Water inlet

temperature) $^\circ\text{C}$ Now, $Q_{cc} = - K_{cc} [dT/dx] \cdot A_{cc}$

$$A = \text{Cross sectional area of the bar} = 0.00049 \text{ m}^2$$

$$K_{cc} = \dots\dots\dots \text{ W/ m } ^\circ\text{C}$$

2) Heat passing through section BB

$$Q_{bb} = Q_{cc} + \text{Radial heat loss between CC \& BB}$$

Where, $2\pi \cdot K L_1 (T_6 - T_{10})$

$$= Q_{cc} + \dots\dots\dots$$

$$\text{Loge } (r_o / r_i)$$

k = Thermal conductivity of insulation

$$= 0.35 \text{ W/m}^\circ\text{C}$$

L_1 = Length of insulation cylinder

$$= 0.060 \text{ m}$$

r_o = outer radius

$$= 0.105 \text{ m}$$

r_i = inner radius

Heat Transfer Lab (LC –ME-314G)

$$Q_{bb} = - K_{bb} [dT/dx]_{bb} .A$$

$$K_{bb} = \dots\dots\dots W/m^{\circ}C$$

- 3) Similarly, heat passing through section AA
 $Q_{aa} = Q_{bb} + \text{Radial heat loss between BB \& AA}$

$$= Q_{bb} + \frac{2\pi \cdot K L_2 \cdot (T_3 - T_9)}{\text{Loge}(r_o / r_i)}$$

Where

$$L_2 = 0.090 \text{ m}$$

$$Q_{aa} = - K_{aa} [dT/dx]_{aa} .A$$

$$K_{aa} = \dots\dots\dots W/m^{\circ}C$$

Conclusion:-

- 1) Thermal conductivity of metal rod is found out to be -----

Experiment No. -2

Aim: To determine the thermal conductivity of an insulating powder.

INTRODUCTION

Conduction of heat is flow of heat which occurs due to exchange of energy from one molecule to another without appreciable motion of molecules. In any heating process, heat is flowing outwards from heat generation point. In order to reduce losses heat, various types of insulation's are used in practice. Various powders e.g. asbestos powder, plaster of paris etc, are also used for heat insulation. In order to determine the appropriate thickness of insulation, knowledge of thermal conductivity material is essential. The unit enables to determine the thermal conductivity of insulating powders, using 'sphere in sphere' method.

APPARATUS

The apparatus consists of a smaller (inner) sphere, inside which is fitted a mica electric heater. Smaller sphere is fitted at the center of outer sphere. The insulating powder, whose thermal conductivity is to be determined, is fitted in the gap between the two spheres. The heat generated by the heater flows through the powder to the outer sphere. The outer sphere loses heat to atmosphere. The input to the heater is controlled by a dimmerstat and is measured on voltmeter and ammeter. Four thermocouples are provided on the outer surface of inner sphere and six thermocouples are on the inner surface of outer sphere, which are connected to multichannel digital temperature indicator. Average of outer & inner sphere temperatures give the temperature difference across the layer of powder.

SPECIFICATION:

- INNER SPHERE – 100 mm O.D., halved construction.
- OUTER SPHERE – 200 mm I.D., halved construction.
- HEATER – Mica flat heater, fitted inside inner sphere.
- CONTROLS – 1) Main Switch – 30 A , DPDT Switch
2) Dimmerstat – 0-230 volts, 2A capacity
- MEASUREMENTS-
 - 1) Voltmeter – 0-200 volts
 - 2) Ammeter- 0-1 Amp.
 - 3) Multichannel digital temperature indicator, calibrated for cr/Al thermocouples.

PROCEDURE:

- Keep dimmerstat knob at ZERO position and switch ON the equipment.
- Slowly rotate the dimmerstat knob, so that voltage is applied across the heater. Let the temperature rise.

Heat Transfer Lab (LC –ME-314G)

- Wait until steady state is reached.
- Note down the temperatures and input of heater in terms of volts and current.
- Repeat the procedure for different heat input.

OBSERVATIONS:

Sr. No.	TEMPERATURES °C										HEATER INPUT	
	T ₁	T ₂	T ₃	T ₄	T ₅	T ₆	T ₇	T ₈	T ₉	T ₁₀	Volts	Amps



THEORY :

Consider the transfer of heat by conduction through the wall of a hollow sphere formed of insulating powder (Ref. fig.)

Let, r_i = radius of inner sphere, m

r_o = radius of outer sphere, m

T_i = avg. inner sphere temperature °c

Heat Transfer Lab (LC –ME-314G)

T_o = avg. outer sphere temperature °C

Consider a thin spherical layer of thickness dr at radius r & temperature difference of dT across the layer. Applying Fourier Law of heat conduction, heat transfer rate,

$$q = -k \cdot 4\pi \cdot r^2 \cdot [dT/dr]$$

Where, k = thermal conductivity of insulating powder

$$\frac{q}{4\pi k} \times \frac{dr}{r^2} = -dT$$

Integrating between, r_i to r_o & T_i to T_o , we get

$$\frac{q}{4\pi k} \int_{r_i}^{r_o} \frac{dr}{r^2} = - \int_{T_i}^{T_o} dT$$

or
$$Q/4\pi k \times [1/r_i - 1/r_o] = (T_i - T_o)$$

or
$$q = \frac{4\pi \cdot k \cdot r_i \cdot r_o \cdot (T_i - T_o)}{(r_o - r_i)}$$

From the measured value of q , T_i and T_o thermal conductivity of insulating powder can be determined as,

$$k = \frac{q (r_o - r_i)}{4\pi \cdot r_i \cdot r_o \cdot (T_i - T_o)}$$

- Heater input ; $q = V \times I$ watts
- Avg. inner sphere surface temperature

$$T_1 + T_2 + T_3 + T_4$$

$$T_i = \frac{\dots}{4} \text{ } ^\circ\text{C}$$

- Avg. outer sphere surface temperature

$$T_5 + T_6 + T_7 + \dots + T_{10}$$

$$T_o = \frac{\dots}{6} \text{ } ^\circ\text{C}$$

Heat Transfer Lab (LC –ME-314G)

- Inner sphere radius = 50 mm = 0.05 m
- Outer sphere radius = 100 mm = 0.10 m

$$q \cdot (r_o - r_i)$$

Now, $k = \dots\dots\dots$ W/m K

$$4 \cdot \pi \cdot r_i \cdot r_o \cdot (T_i - T_o)$$

PRECAUTIONS:

- Operate all the switches and control gently.
- If thermal conductivity of the powder other than supplied is to be determined, then gently dismantle the outer sphere and remove the powder, taking care that heater connections and thermocouples are not disturbed.
- Earthing is essential for the unit.

Schematic Diagram:

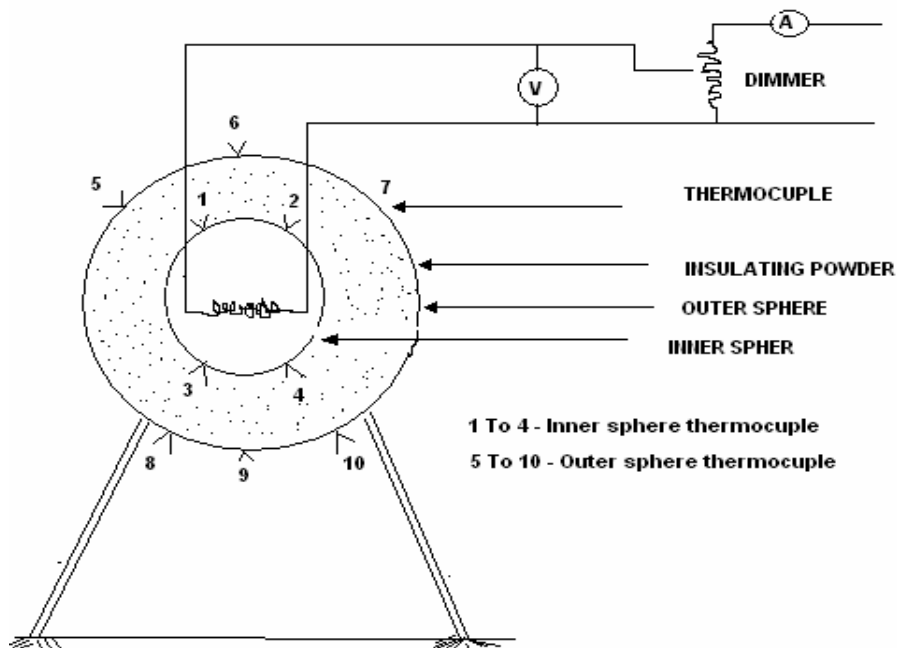

RESULTS : The thermal conductivity of an insulating powder =

Experiment No. -3

Aim: To determine the thermal conductivity of a solid by the guarded hot plate method.

GENERAL DESCRIPTION:

The apparatus is designed and fabricated according to the Guarded Hot Plate Principle. The guarded hot plate method has been recognized by scientists and engineers in U.S.A., West Germany, Scandinavian Countries, USSR and India as most dependable and reproducible for the measurement of thermal conductivity of insulating materials. It is a steady state absolute method suitable for materials which can be laid flat between two parallel plates and can be adopted for loose fill materials which can be filled between such plates.

PRINCIPLES OF THE GUARDED HOT PLATE METHOD:

The essential parts- the hot plate, the cold plates, the heater assembly, thermocouples and the specimens in position are shown in the same figure.

For the measurement of thermal conductivity (k) what is required is to have a one dimensional heat flow through the flat specimen, an arrangement for maintaining its faces at constant temperature and some metering method to measure the heat flow through a known area. To eliminate the distortion caused by edge losses in unidirectional heat flow, the central plate is surrounded by a guard which is separately heated. Temperatures are measured by calibrated thermocouples either attached to the specimens at the hot and cold faces. Two specimens are used to ensure that all the heat comes not through the specimen only. Knowing the heat input to the central plate heater, the temperature difference across the specimen, its thickness and the metering area, one can calculate K of the specimen by the following formula:

$$K = \frac{q}{2A} \times \frac{L}{T_h - T_c} \text{ W/m } ^\circ\text{C} \dots\dots\dots (1)$$

- Where, K = Thermal conductivity of sample, W/m °C
q = Heat flow rate in the specimen, Watts
A = Metering area of the specimen,
T_h = Hot plate temperature, °C
T_c = Cold plate temperature, °C
L = Thickness of specimen, m

If the specimen thickness are different and the respective hot and cold temperatures are different then

Heat Transfer Lab (LC –ME-314G)

$$K = \frac{q}{A \times (a + b)} \text{ W/ m } ^\circ\text{C}$$

$$\text{Where, } a = \frac{1}{(T_{h1} - T_{c1})/L_1}$$

$$b = \frac{1}{(T_{h2} - T_{c2})/L_2}$$

Where suffix 1 is for upper specimen and 2 is for lower specimen.

APPARATUS:

The apparatus is designed and fabricated with IS 3336 as a guide line, having the following specifications :

- Diameter of the heating plate = 100 mm
- Width of the heating plate = 037 mm
- Inside diameter of the heating ring = 110 mm
- Outside diameter of the heating ring = 180 mm
- Max. thickness of the specimen = 025 mm
- Min. thickness of the specimen = 006 mm
- Diameter of the specimen = 180 mm
- Mean temperature range = 40 °c – 100 °C
- Max. temperature of hot plate = 170 °C
- Diameter of cooling plate = 180 mm
- Central Heater - Nichrome strip type wire sandwiched between mica sheets.
- Guarded Heater Rig - Nichrome strip type wire sandwiched between mica sheets.
- Dimmerstat - (0-2 Amp, 0-240 Volts.) - 2 Nos.
- Voltmeter - 0-200 V.
- Ammeter - 0-2 Amp.
- Thermocouple - (Chromel Alumel) - 6 Nos.
- Glass wool insulation around the assembly.
- Temperature Indicator - 0-200 °c
- Specimen supplied - Hylam (Backelite) 9.5 mm thick.

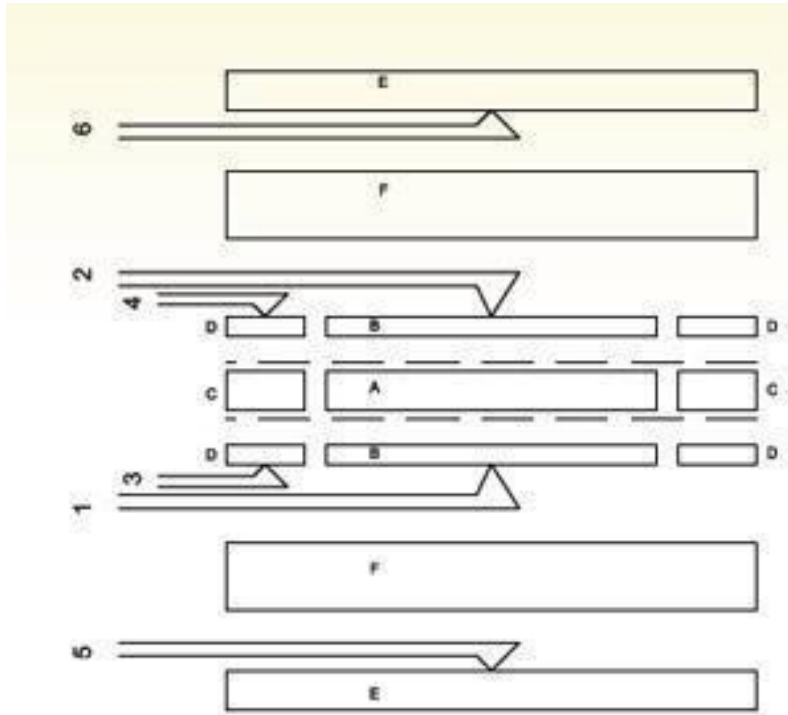

DISCRIPTION:

The heater plate is surrounded by a heating ring for stabilizing the temperature of the primary heater and prevent heat loss radially around its edges. The primary and guard heater are made up of mica sheets in which is wound closely spaced Nichrome wire and packed with upper and lower mica sheets. These heaters together form a flat which together with upper and lower copper plates and rings form the heater plate assembly.

Two thermocouples are used to measure the hot face temperature at the upper and lower central heater assembly copper plates. Two more thermocouples are used to check balance in both the heater. Specimens are held between the heater and cooling unit on each side of the apparatus. Thermocouple No. 5 and 6 measure the temperature of the upper cooling plate and lower cooling plate respectively.

The cooling chamber is a composite assembly of Aluminium casting and Aluminium cover with entry and exit adapter for water inlet and outlet.

TEST PROCEDURE:

The specimens are placed on either side of the plate assembly, uniformly touching the cooling plate. The outer container containing glass wool insulation is fixed over the test assembly carefully. The cooling circuit is started. Then input is given to central and guard heaters through separate single phase supply lines with a dimmerstat for each line and it is adjusted to maintain the desired temperatures. The guard heater input is adjusted in such a

Heat Transfer Lab (LC –ME-314G)

way that there is no radial heat flow which is checked from thermocouple readings and is adjusted accordingly. The input to the central heater (current and voltage) the thermocouple readings are recorded every 10 minutes till a reasonably steady state condition is reached. The readings are recorded in the observation table. The final steady state values are taken for calculation.

PRECAUTIONS:

- Keep dimerstat to ZERO voltage position before start.
- Increase the voltage gradually.
- Start the cooling circuit before switching ON the heaters and adjust the flow rate so that practically there is no temperature rise in the circulation.
- Keep the heater plate undisturbed and adjust the cooling plate after keeping the samples with the help of nuts gently.
- While fixing the insulation cover, be careful that heater and thermocouple connections as well as water connections are not disturbed.

OPERATIONAL INSTRUCTIONS:

For insuring that no radial heat transfer is there, generally outer heater input is about 2 to 3 times than central heating input.

OBSERVATION TABLE :

Sr No.	Main Heater				Ring Heater				Cooling Plate	
	V	I	T ₁	T ₂	V	I	T ₃	T ₄	T ₅	T ₆

CALCULATIONS :

- Main Heater Input = $V_1 \times I_1 = W_1$
(Inner Heater)
- Ring Heater Input = $V_2 \times I_2 = W_2$
(Outer Heater)
- Specimen Used =
- Specimen thickness 'L' =
- Diameter of specimen = 0.180 m
- Metering area π
 $A = \dots\dots\dots \frac{\pi (D + X)^2}{4} = 0.00866 \text{ m}^2$

Heat Transfer Lab (LC –ME-314G)

Where, D = Dia. of the heating plate = 0.1 m
 X = Width of gap between the plates = 0.005 m

$$W_1 \times L$$

$$\text{➤ } K = \frac{\dots\dots\dots}{2A \cdot (T_h - T_c)} \quad \text{W/m}^\circ\text{C}$$

Referred at,

$$T_h + T_c$$

$$= \frac{\dots\dots\dots}{2}$$

Where,

$$T_1 + T_2$$

$$T_h = \frac{\dots\dots\dots}{2} \quad ^\circ\text{C}$$

$$T_5 + T_6$$

$$T_c = \frac{\dots\dots\dots}{2} \quad ^\circ\text{C}$$

Results: The thermal conductivity of a solid=

Experiment No. -4 & 5

Aim: To find the effectiveness of a pin fin in a rectangular duct natural & Forced convective condition and plot temperature distribution along its length.

INTRODUCTION

Extended surface or fins are use to increase the heat transfer rates from a surface to the surrounding fluid wherever it is not possible to increase the value of the surface heat transfer coefficient or the temperature difference between the surface and the fluid. Fins are fabricated in variety of form. Fins around the air cooled engines are common examples.

As the fins extend from primary heat transfer surface, the temperature difference with the surrounding fluid diminishes towards the tip of the fin. The aim of the experiment is to study the temperature distribution and the effectiveness of the fin, which play an important role in design.

The apparatus consist of a simple pin fin which is fitted in a rectangular duct. The duct is attached to suction end of blower. One end of fin is heated by an electrical heater. Thermocouples are mounted along the length of fin and a thermocouple notes the duct fluid temperature. When top cover over the fin is opened and heating started, performance of fin with natural convection can be evaluated and with top cover closed & blower started, fin can be tested in forced convection.

Specification

1) Fins-12 mm O.D., effective length 102 mm with 5 Nos. of thermocouple position along with the length, made of brass, mild steel of aluminum-one each.

Fin is screwed in heater block which is heated by a band heater.

2) Duct-150*100 mm cross section,1000 mm long connected to suction side of blower.

3) F.H.P centrifugal blower with orifice and flow control valve on discharge side.

4) Orifice-dia. 22 mm coefficient of discharge $C_d=0.64$.

5) Measurement and control

a) Dimmer stat to control heater input, 0-230 V, 2 amp.

b) Voltmeter 0-250 V, for heater supply voltage.

Heat Transfer Lab (LC –ME-314G)

- c) Ammeter 0-1 amp. for heater current.
- d) Multichannel digital temperature indicator.
- E) Water manometer connected to orifice meter.

Theory-

Let A = cross section area of the fin, m²

P = circumference of the fin, m

L = length of fin=0.102 m.

T₁= Base temperature of the fin.

T_f = Duct fluid temperature (channel No. 6 of temperature indicator)

Ø = Temperature difference of fin and fluid temperature

$$= T - T_f$$

h = heat transfer coefficient, w/m² °C.

K_f = Thermal conductivity of the fin material.

= 110 W/ m K for brass

= 46 W/ m K for mild steel

= 232 W/ m K for aluminum

Heat is conducted along the length of fin and also lost to surrounding. Applying first law of thermodynamics to a control volume along the length of fin at a station which is at length 'x' from the base,

$$d^2T - h \cdot \frac{\delta}{k_f A} = 0$$

$$\frac{d^2T}{dx^2} - \frac{h \cdot \delta}{k_f A} = 0 \dots\dots\dots 1$$

$$\delta = (C_1 \cdot e^{mx}) + (C_2 \cdot e^{-mx}) \dots\dots\dots 2$$

$$\text{Where, } m = \sqrt{\frac{h \cdot P}{k_f \cdot A}} \dots\dots\dots 3$$

Heat Transfer Lab (LC –ME-314G)

With the boundary conditions of $\theta = \theta_1$ at $x = 0$

$$= \frac{\cos m(L-x)}{\cosh ml} \dots\dots\dots 4$$

$\theta_1 = T_1 - T_f$, assuming tip to be insulated.

$$\frac{d\theta}{dx} = 0 \text{ at } x = L$$

L results in obtaining equation (2) in the form

$$\frac{\theta}{\theta_1} = \frac{T - T_f}{T_1 - T_f}$$

This is the equation for temperature distribution along the length of the fin. Temperatures T_1 and T_f will be known for the given situation and the value of ‘h’ depends upon mode of convection i.e. natural or forced.



Heat Transfer Lab (LC –ME-314G)

EXPERIMENTAL PROCEDURE

A) NATURAL CONVECTION

Open the duct cover over the fin. Ensure proper earthing to the unit and switches on the main supply. Adjust dimmerstat so that about 80 volts are supplied to the heater. The fin will start heating. When the temperatures remain steady, note down the temperatures of the fin and duct fluid temperature. Repeat the experiment at different inputs to heater.

OBSERVATION-

Sr. NO	Input		Fin temperature °C					Duct fluid temp °C
	V	I	T ₁	T ₂	T ₃	T ₄	T ₅	T ₆

A) FORCED CONVECTION-

Close the duct cover over the fin. Start the blower. Adjust the dimmerstat so that about 100-110 volt are supplied to the heater. When the temperatures become steady, note down all the temperatures and the manometer difference.

Repeat the experiment at different inputs and at different air flow rates.

OBSERVATIONS TABLES-

Sr. No.	Manometer difference	Fin Temperature °C					Duct fluid temperature °C
	H (m of water)	T ₁	T ₂	T ₃	T ₄	T ₅	T ₆ = T _f

CALCULATION-

NOMENCLATURE-

T_m = Average fin temperature = $(T_1 + T_2 + T_3 + T_4 + T_5)$

$$\Delta T = T_m - T_f$$

T_{mf} = mean film temperature = $(T_m + T_f)/2$

ρ_a = Density of air, kg/m^3

ρ_w = Density of water, kg/m^3

D = Diameter of pin fin = 12×10^{-3} m.

d = Diameter of orifice = 22×10^{-3} m.

C_d = coefficient of discharge of orifice = 0.64

μ = Dynamic viscosity of air, N-s/m^2

C_p = Specific heat of air, $\text{kJ/kg}^\circ\text{C}$

ν = Kinematic viscosity, m^2/s .

K_{air} = Thermal conductivity of air, $\text{W/m}^\circ\text{C}$

β = volume expansion coefficient = $1/(T_{mf} + 273)$

H = manometer difference, m of water

V = velocity of air in duct, m/s

Q = volume flow rate of air, m^3/s

V_{tmf} = velocity of air at mean film temperature.

All properties are to be evaluated at mean film temperature.

NATURAL CONVECTION-

The fin under consideration is horizontal cylinder losing heat by natural convection. For horizontal cylinder, Nusselt number,

$$Nu = 1.10 (Gr \cdot Pr)^{1/6} \text{ ----- for } 10^{-1} < Gr \cdot Pr < 10^4.$$

$$Nu = 0.53 (Gr \cdot Pr)^{1/4} \text{ ----- for } 10^4 < Gr \cdot Pr < 10^9.$$

Heat Transfer Lab (LC –ME-314G)

Where, Gr = Grashof number,

$$= (\beta \cdot g \cdot D^3 \cdot \Delta T) / \nu^2$$

Pr = Prandtl number

$$= (C_p \cdot \mu) / k_{\text{air}}$$

Determine Nusselt number

Now, $Nu = (h \cdot D) / k_{\text{air}}$

$h =$

From h , determine 'm' from equation (3)

Using h and m , determine temperature distribution in the fin from equation (4).

The rate of heat transfer from the fin can be calculated as

$$q = (h \cdot P \cdot k_f \cdot A)^{1/2} \cdot (T_1 - T_f) \tanh mL \dots \dots \dots 5$$

and efficiency of the fin can be calculated as,

$$\eta = \frac{(\tanh mL)}{mL} \dots \dots \dots 6$$

Forced Convection –

As in natural convection, for horizontal cylinder losing heat by forced convection,

$$Nu = 0.065 (Re)^{0.466} \dots \dots \dots \text{for } 40 < Re < 4000$$

$$Nu = 0.174 (Re)^{0.618} \dots \dots \dots \text{for } 4000 < Re < 40000$$

Where,

$$Re = \frac{V_{tmf} \cdot D}{\nu}$$

$$V_{tmf} = \frac{(T_m f + 273)}{(T_f + 273)}$$

Velocity of air is determined from air volume flow

$$Q = C_d \frac{\pi}{4} d^2 \sqrt{2 \cdot g \cdot H (p_w - p_a)} \quad \text{m}^3 / \text{s}$$

$$V = Q / \text{Duct cross sectional area}$$

$$= Q / (0.15 \times 0.1) \quad \text{m} / \text{s}$$

Heat Transfer Lab (LC –ME-314G)

Now temperature distribution, heat transfer rate and effectiveness of the fin can be calculated using equation 4,5 and 6 respectively.

Conclusion –

- 1) Comment on the observed temperature distribution and calculation by theory, it is expected that observed temperatures should be slightly less than their calculated values because of radiation and non-insulated tip.
- 2) Plot the graphs of temperature distribution in both natural and forced convection.

Precautions

- 1) Operate all the switches and controls gently.
- 2) Do not obstruct the suction of the duct or discharge pipe.
- 3) Open the duct cover the fin for normal convection experiment.
- 4) Fill up water in the manometer and closed duct cover for forced convection experiment.
- 5) Proper earthing to unit is necessary.
- 6) While replacing the fins, be carefully for the fixing the thermocouples. Incorrectly fixed thermocouples may show erratic readings.

Schematic Diagram

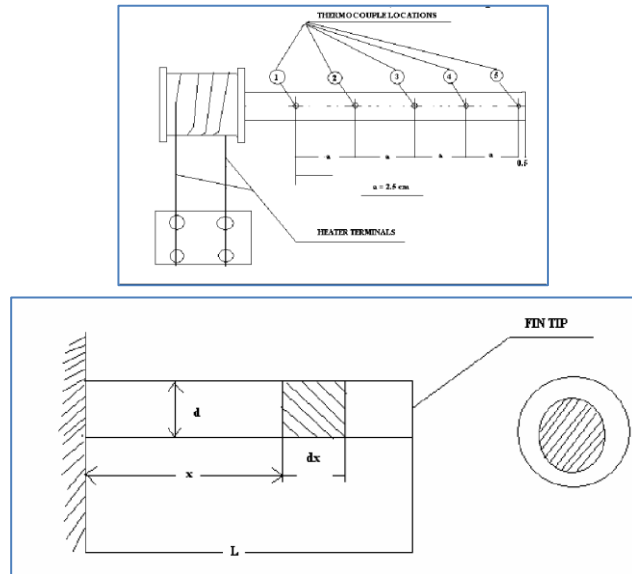

Results: 1. The effectiveness of a pin fin in a rectangular duct natural convection

2. The effectiveness of a pin fin in a rectangular duct Forced convective

Experiment No. -6

Aim: To determine the surface heat transfer coefficient for a heated vertical tube under natural convection and plot the variation of local heat transfer coefficient along the length of the tube. Also compare the results with those of the correlation.

INTRODUCTION:

In contrast to the forced convection, natural convection phenomenon is due to the temperature difference between the surface and the fluid and is not created by any external agency. The present experimental set up is designed and fabricated to study the natural convection phenomenon from a vertical cylinder in terms of the variation of local heat transfer coefficient along the length and also the average heat transfer coefficient and its comparison with the value obtained by using an appropriate correlation.

APPARATUS:

The apparatus consists of a brass tube fitted in a rectangular vertical duct. The duct is open at the top and forms an enclosure and serves the purpose of undisturbed surrounding. One side of the duct is made up of perspex for visualization. An electric heating element is kept in the vertical tube which in turns heat the tube surface. The heat is lost from the tube to the surrounding air by natural convection. The temperature of vertical tube is measured by seven thermocouples. The heat input to the heater is measured by an ammeter and a voltmeter and is varied by a dimmerstat. The tube surface is polished to minimize the radiation losses.

SPECIFICATION:

- Diameter of the tube (d) = 38 mm
- Length of the tube (L) = 500 mm
- Duct size 200 mm × 200 mm × 800 mm Length
- Multichannel Digital Temperature Indicator 0 – 300 °C using Chromel/Alumel thermocouple.
- Ammeter 0 – 2 Amp. and Voltmeter 0 – 200 Volts.
- Dimmerstat 2 Amp. 240 Volts.

THEORY:

When a body is kept in still atmosphere, heat is transferred to the surrounding fluid by natural convection. The fluid layer in contact with the hot body gets heated, rises up due to the decrease in its density and the cold fluid rushes in to take place. The process is continuous and the heat transfer takes place due to the relative motion of hot and cold fluid particles.

Heat Transfer Lab (LC –ME-314G)

The heat transfer coefficient is given by :

$$h = \frac{q - q_1}{A_s \times (T_s - T_a)} \quad (1)$$

Where, h = Average surface heat transfer coefficient (W/m²°C)

q = heat transfer rate (Watts)

A_s = Area of heat transferring surface = π.d.l

(m²) T_s = Avg. surface temperature

$$T_s = \frac{T_1 + T_2 + T_3 + T_4 + T_5 + T_6 + T_7}{7} \quad ^\circ\text{C}$$

T_a = Ambient temperature in the duct = T₈ °C

q₁ = heat loss by radiation = σ . A . ε . (T_s⁴ - T_a⁴)

Where, σ = Stefan Boltzmann constant = 5.667 × 10⁻⁸ W/m² K⁴

A = Surface area of pipe = 0.59 m²

ε = Emissivity of pipe material = 0.6

T_s & T_a = Surface and ambient temperatures in °K

For gases, β = $\frac{1}{(T_f + 273)}$ /°K

(T_s + T_a)

$$T_f = \frac{2}{\dots}$$

For a vertical cylinder losing heat by natural convection, the constant ‘A’ & ‘n’ of equation (2) have been determined and the following empirical correlation’s obtained.

$$\frac{h \times L}{k} = 0.59 (\text{Gr} \cdot \text{Pr})^{0.25} \quad \text{For } 10^4 < \text{Gr} \cdot \text{Pr} < 10^8 \quad (3)$$

$$\frac{h \times L}{K} = 0.13 (\text{Gr} \cdot \text{Pr})^{0.333} \quad \text{For } 10^8 < \text{Gr} \cdot \text{Pr} < 10^{12} \quad (4)$$

L = Length of cylinder

All the properties of the fluid are determined at the mean film temperature (T_f)

Heat Transfer Lab (LC –ME-314G)

PROCEDURE:

- Put ON the supply and adjust the dimmerstat to obtain the required heat input - (Say 40 W, 60 W, 70 W etc.)
- Wait till the steady state is reached, which is conformed from temperature readings – (T₁- T₇).
- Measure surface temperature at the various points i.e. T₁ to T₇.
- Note the ambient temperature i.e. T₈
- Repeat the experiment at different heat input (**Do not exceed 80 w**)

OBSERVATIONS:

- O.D. cylinder = 38 mm.
- Length of cylinder = 500 mm.
- Input to heater = V × I Watts.

Sr. No.	Volt	Amp.	TEMPERATURE °C							
			T ₁	T ₂	T ₃	T ₄	T ₅	T ₆	T ₇	T ₈

CALCULATION:

- Calculate the value of average heat transfer coefficient, neglecting end losses using equation (1).
- Calculate and plot (Fig. 4) the variation of local heat transfer coefficient along the length of the tube.

$$T = T_1 \text{ to } T_7 \text{ and } h = \frac{q}{A_s \cdot (T - T_a)}$$

- Compare the experimentally obtained value with the predictions of the correlation equations (3) Or (4).

NOTE: The heat loss due to the radiation and conduction is not considered, but they are present, which give difference between actual and theoretical values.

PRECAUTIONS:

- Proper earthing is necessary for the equipment.
- Keep dimmerstat to ZERO volt position before putting ON main switch and

Heat Transfer Lab (LC –ME-314G)

increase it slowly.

- Keep at least 200 mm space behind the equipment.
- Operate the change-over switch of temperature indicator gently from one position to other i.e. from 1 to 8 position.
- **Never exceed input above 80 Watts.**

RESULT AND DISCUSSIONS –

The heat transfer coefficient is having a maximum value at the beginning as expected because of the just starting of the building of the layer and it decreases as expected in the upward direction due to thickening of layer and which is laminar one. This trend is maintained up to half of length (approx.) and beyond that there is little variation in the value of local heat transfer coefficient because of the transition and turbulent boundary layers. The last point shows somewhat increase in the value of heat transfer coefficient which is attributed to end loss causing a temperature drop.

The comparison of average heat transfer coefficient is also made with predicted values are somewhat less than experimental values due to the heat loss by radiation.

$$\text{Heat loss by radiation} = \sigma \cdot \varepsilon \cdot A \cdot (T_s^4 - T_a^4)$$

Where, σ = Stefan Boltzmann constant = $5.667 \times 10^{-8} \text{ W/m}^2 \text{ K}^4$

$$A = \text{Surface area of pipe} = 0.59 \text{ m}^2$$

$$\varepsilon = \text{Emissivity of pipe material} = 0.6$$

T_s & T_a = Surface and ambient temperatures in $^{\circ}\text{K}$

PROPERTIES OF AIR

T	ρ	C_p	$\mu \times 10^6$	K	Pr	$\nu \times 10^6$
$^{\circ}\text{C}$	Kg/m^3	KJ/kg-k	N-sec/m^2	w/m-k		m^2/sec
0	1.293	1.005	17.2	0.0244	0.707	13.28
10	1.247	1.005	17.7	.0251	0.705	14.16
20	1.205	1.005	18.1	0.0259	0.703	15.06
30	1.165	1.005	18.6	0.0267	0.701	16.00
40	1.128	1.005	19.1	0.0276	0.699	16.96
50	1.093	1.005	19.6	0.0283	0.698	17.95
60	1.060	1.005	20.1	0.0290	0.696	18.97
70	1.029	1.009	20.6	0.0297	0.694	20.02
80	1.000	1.009	21.1	0.03035	0.692	21.09
90	0.972	1.009	21.5	0.0313	0.690	22.10

Heat Transfer Lab (LC –ME-314G)

Experiment No. -7

Aim: To determine average heat transfer coefficient for a externally heated horizontal pipe under forced convection & plot Reynolds and Nusselt numbers along the length of pipe. Also compare the results with those of the correlations.

INTRODUCTION

Whenever a fluid is being forced over the heated surface, forced convection heat transfer occurs. The apparatus consists of a circular pipe, through which cold fluid, i.e. air is being forced. Pipe is heated by a band heater outside the pipe. Temperature of pipe is measured with thermocouples attached to pipe surface. Heater input is measured by a Voltmeter and Ammeter. Thus, heat transfer rate and heat transfer coefficient can be calculated.

SPECIFICATIONS:

- Test pipe – 33 mm I.D. 500 mm Long.
- Band heater for pipe.
- Multichannel Digital Temperature Indicator 0-300 °C using Chromel/ Alumel thermocouples.
- Dimmerstat 2Amps. 240 volts. for heater input control.
- Voltmeter 0-200 Volts.
- Ammeter 0-2 Amps.
- Blower to force the air through test pipe
- Orifice meter with water manometer.

PROCEDURE:

- Put ON mains supply.
- Adjust the heater input with the help of dimmerstat.
- Start the blower and adjust the air flow with valve.
- Wait still steady state is reached and note down the reading in the observation table.

OBSERVATIONS:

Sr. No.	Volt	Amp.	Temperature °C							Manometer Difference
	V	I	T ₁	T ₂	T ₃	T ₄	T ₅	T ₆	T ₇	h _w

Heat Transfer Lab (LC –ME-314G)

CALCULATIONS:

- Air inlet temperature $T_1 = \quad \quad \quad ^\circ\text{C}$
- Air outlet temperature $T_2 = \quad \quad \quad ^\circ\text{C}$
- Density of air

$$\rho_a = \frac{1.293 \times 273}{273 + T_1} \quad \text{Kg/m}^3$$

- Diameter of orifice = 22 mm
Manometer difference = water head = h_w mtrs

$$\text{Air heads, } h_a = h_w (\rho_w - \rho_a)$$

Where, $\rho_w = \text{Density of water} = 1000 \text{ Kg/m}^3$

Air volume flow rate

$$Q = C_d \times a_o \times (2.g.h_a)^{1/2} \quad \text{m}^3/\text{sec}$$

Where, $C_d = 0.64$

$a_o = \text{c.s. area of pipe}$

- Mass flow rate of air

$$m_a = Q \times \rho_a \quad \text{kg/s}$$

Where, Velocity of air, $V = \dots\dots\dots \text{ m/sec}$

$a_p = \text{cross sectional area of pipe}$

$$= 8.33 \times 10^{-4} \quad \text{m}^2$$

- Heat gained by air, $q = m_a \times c_{pa} \times (T_2 - T_1)$

Where, $c_{pa} = \text{specific heat of air} = 1 \text{ kJ/Kg K OR } 1000 \text{ J/Kg K}$

- Average inside surface temperature,

$$T_2 + T_3 + T_4 + T_5 + T_6$$

$$T_s = \dots\dots\dots \quad \quad \quad ^\circ\text{C}$$

Heat Transfer Lab (LC –ME-314G)

- Bulk mean temperature of air,

$$T_m = \frac{T_1 + T_7}{\dots\dots\dots} \quad ^\circ\text{C}$$

- Average surface heat transfer coefficient

- Actual heat loss due to forced convection = q - heat loss due to radiation

Heat loss due to radiation (q_1):-

$$q_1 = 0.4 \times A \times (T_s^4 - T_a^4) \times \sigma$$

σ = Stefan Boltzmann Constant

Actual heat loss = q - q_1

$$h_{\text{expt}} = \frac{q - q_1}{A \times (T_s - T_m)} \quad \text{W/m}^2 \text{K}$$

Where, A = inside surface area of the pipe = $\pi \times d_i \times l$

$$= \pi \times .033 \times 0.5$$

$$= 0.0518 \text{ m}^2$$

- Reynold's Number :

$$Re_D = \frac{V \times D}{\nu}$$

ν = kinematic viscosity at T_m

$D = 0.033 \text{ m}$

If $Re_D < 2000$, flow is laminar.

For laminar flow $\frac{h \cdot D}{k_{\text{air}}} = 4.36$

If $Re_D > 2000$, flow is turbulent.

Heat Transfer Lab (LC –ME-314G)

For turbulent flow,
 $h \cdot D$

$$Nu_D = \dots\dots\dots$$

$$K_{air} = 0.023 (Re_D)^{0.8} \times (Pr.)^n$$

Where, $n = 0.4$ when fluid is being heated
 $n = 0.3$ when fluid is being cooled

Determine h_{theo} from Nu_D

NOTE: The calculated values and actual values may differ appreciably because of heat losses .the heat loss through natural convection, conduction and heat loss through insulation over the heater is not considered, but they are also present. The heat flux is not uniform practically, as assumed in theory, which gives difference between actual and theoretical value.

Results

The average heat transfer coefficient for a externally heated horizontal pipe under forced convection & plot Reynolds and Nusselt numbers along the length of pipe=

PROPERTIES OF AIR

T	ρ	Cp	$\mu \times 10^6$	K	Pr	$\nu \times 10^6$
°C	Kg/m ³	KJ/kg-K	N-sec/m ²	w/m-K		m ² /sec
0	1.293	1.005	17.2	0.0244	0.707	13.28
10	1.247	1.005	17.7	.0251	0.705	14.16
20	1.205	1.005	18.1	0.0259	0.703	15.06
30	1.165	1.005	18.6	0.0267	0.701	16.00
40	1.128	1.005	19.1	0.0276	0.699	16.96
50	1.093	1.005	19.6	0.0283	0.698	17.95
60	1.060	1.005	20.1	0.0290	0.696	18.97
70	1.029	1.009	20.6	0.0297	0.694	20.02
80	1.000	1.009	21.1	0.03035	0.692	21.09
90	0.972	1.009	21.5	0.0313	0.690	22.10
100	0.946	1.009	21.9	0.0321	0.688	23.13
120	0.898	1.009	22.9	0.0334	0.686	25.45
140	0.854	1.013	23.7	0.0349	0.684	27.80

Experiment No. -8

Aim: To measure the emissivity of the gray body (plate) at different temperature and plot the variation of emissivity with surface temperature.

INTRODUCTION:

All the bodies emit and absorb the thermal radiation to and from surroundings. The rate of thermal depends upon the temperature of body. Thermal radiations are electromagnetic waves and they do not require any medium for propagation.

When thermal radiation strikes a body, part of it is reflected, part of it is absorbed and part of it is transmitted through body.

The fraction of incident energy reflected by the surface is called reflectivity (ρ). The fraction of incident energy absorbed by surface is called absorptivity (α) and the fraction of energy transmitted is called transmissivity (τ). The surface which absorb all the incident radiation is known as a black surface.

For a black surface,

$$\rho + \alpha + \tau = 1$$

The radiant flux, emitted from the surface is called emissive power (e).

The emissivity of a surface is ratio of emissive power of a surface to that of black surface at same temperature. Thus,

$$s = e/e_b$$

THE APPARATUS

The apparatus uses comparator method for determining the emissivity of test plate. It consists of two aluminum plates of equal physical dimensions. Mica heaters are provided inside the plates. The plates are mounted in an enclosure to provide undisturbed surroundings.

One of the plates is blackened outside for use as a comparator. Another plate is having neutral surface finish. Input to heaters can be controlled by separate dimmerstats. Heaters input are measured on common ammeter and voltmeter. One thermocouple is fitted on surface of each plate to measure the surface temperature with digital temperature indicator. By adjusting input to the heaters, both the plates are brought to same temperature, so that conduction and convection losses from both the plates are equal and difference in input is due to different emissivity.

Holes are provided at black side bottom and at the top of enclosure for natural circulation of air over the plates. The plate is provided with perplex acrylic sheet at the front.



EXPERIMENTAL PROCEDURE

1. Blacken one of the plates with the help of lamp black (Normally this is blackened at the works, but if blackening is wiped out, then blackening is necessary)
2. Keep both the dimmer knobs at ZERO position.
3. Insert the supply pin-top in the socket (which is properly earthed) and switch 'ON' the mains supply.
4. Switch ON the mains switch on the panel.
5. Keep the meter selector switch (toggle switch) at the black plate side position.
6. Adjust dimmer of black plate, so that around 110- 120 volts are supplied to black plate.
7. Now, switch the meter selector switch on other side.
8. Adjust test plate voltage slightly less than that of black plate (say 100- 110 volts)
9. Check the temperatures (after, say 10 minutes) and adjust the dimmers so that temperatures of both the plates are equal and steady. Normally, very minor adjustments are required for this.
10. Note down the readings after the plates temperatures reach steady state.

OBSERVATIONS

Plate	Input		Surface Temp °C
	V	I	
Test Plate			T ₁ =
Black Plate			T ₂ =

Enclosure Temperature = T₃ °C

CALCULATIONS

1. Enclosure Temperature

$$T_E = T_3 \text{ °C}$$

Heat Transfer Lab (LC –ME-314G)

2. Plates surface temperature

$$T = T_1 = T_2 = \quad ^\circ\text{C}$$

$$T_S = (T + 273.15) \text{ } ^\circ\text{K}$$

3. Heat input to black plate,

$$W_b = V \times I \text{ Watts}$$

4. Heat input to test plates,

$$W_T = V \times I \text{ watts}$$

5. Surface area of plates

$$A = 2 \times \frac{\pi D^2}{4} + [\pi \times D \times t]$$

$$= 0.0447 \text{ m}^2$$

Where, D = dia. of plates = 0.16 m.

And, t = thickness of plates = 0.009 m.

6. For black plates,

$$W_b = W_{CVb} + W_{Cdb} = W_{Rb} \text{-----(1)}$$

Where,

W_{CVb} = Convection losses

W_{Cdb} = Conduction losses

W_{Rb} = Radiation losses

Similarly, for test plate,

$$W_T = W_{CVT} + W_{CDT} + W_{RT} \text{-----(2)}$$

As both plates are of same physical dimensions, same material & at same temperatures,

$$W_{CVb} = W_{CVT} \text{ \& } W_{Cdb} = W_{CDT}$$

Subtracting equation 2 from 1 , we get,

$$W_b - W_T = W_{Rb} - W_{RT}$$

$$= [\sigma \cdot A \cdot \epsilon_b (T_S^4 - T_E^4)] - [\sigma \cdot A \cdot \epsilon_T \cdot (T_S^4 - T_E^4)]$$

$$= [\sigma \cdot A \cdot (T_S^4 - T_E^4) (\epsilon_B - \epsilon_T)]$$

As emissivity of black plate is 1 ,

$$W_b - W_T = \sigma \cdot A \cdot (T_S^4 - T_E^4) (1 - \epsilon_T)$$

Where ,

Heat Transfer Lab (LC –ME-314G)

ϵ =emissivity of test plate

σ =Stefan Boltzman constant = 5.667×10^{-8} w/m² K⁴

Note- Emissivity of oxidized aluminium plate i.e. test plate is normally within in the range of 0.3 to 0.7

PRECAUTIONS

- (1) Black plate should be perfectly blackened.
- (2) Never put your hands or papers over the holes provided at the top of enclosure.
- (3) Keep at least 200 mm distance between the back side of unit and the wall
- (4) Operate all the switches and knobs gently.

Results

The test plate was found to be..... at a temperature of °K

Experiment No. -9

Aim: To find overall heat transfer coefficient and effectiveness of a heat exchange under parallel and counter flow conditions. Also plot the temperature distribution in both the cases along the length of heat of heat exchanger.

INTRODUCTION

SHELL AND TUBE HEAT EXCHANGER APPARATUS

Heat exchanger is the device used to transfer the heat from one fluid to another. Transfer of heat is needed for many applications. Commonly used types of heat exchanger are transfer type, storage type and direct contact type, both, hot and cold fluids are passing simultaneously through the heat exchanger and heat is being transferred through the separating wall between them. Transfer type heat exchangers are simple for connection are installations and hence are used in many applications.

In transfer type heat exchanger, different type of flow arrangements are used, viz, parallel, counter or cross flow. The shell and tube heat exchanger is two pass heat exchanger. The hot fluid is hot water obtained from water heater. The cold fluid is tap water. The schematic flow arrangement is shown in fig. Hot water enters the lower side of end box, flows through the tubes in lower half of shell and comes to the other end of the shell, where it reverses its direction, flows through tubes in upper half of the shell and leaves out. Cold water enters lower part of the shell passes over the tubes between the baffles and leaves out the shell through outlet at upper surface of shell.

SPECIFICATION

- 1) Shell -150 NB, 750 m. m long provided with end boxes.
- 2) One end box with divider plate.
- 3) 25% cut baffles – 4 Nos. in the shell.
- 4) Tubes – 4.5 I.D., 6.35 O.D., 750 m. m. copper with triangular pitch.- 32 Nos.
- 5) Instantaneous water heater, 3 kW capacity, to supply hot water.
- 6) Thermometer for measuring the water temperature.
- 7) Valves to control hot and cold water flow.

SERVICES REQUIRED FROM CUSTOMER-

- 1) Water supply about 10 lit/min at constant head.
- 2) 230V, 16A AC supply.
- 3) Floor space of about 1.5 mtr × 1mtr.
- 4) Suitable drain arrangement for water.

Heat Transfer Lab (LC –ME-314G)

EXPERIMENTAL PROCEDURE-

- 1) Connect the water supply and start water flow, for heat water (tube side) keep flow rate above 2.5 Lit/min (maximum flow rate is 7 Lit/min), keep cold water (shell side) flow rate between 3 to 8 Lit/min.
- 2) Connect the main electric supply (250V, 15 A) and switch 'ON' the water heater.

NEVER SWITCH ON THE HEATER BEFORE STARTING WATER SUPPLY-

- 3) Observe water inlet and outlet temperatures.
- 4) Wait till steady state is reached and note down the observation
- 5) Repeat the procedure by changing the water flow rate.

OBSERVATION-

Sr. No	HOT WATER			COLD WATER		
	Inlet temp' $T_{hi} \text{ }^\circ\text{C}$	Outlet temperature $T_{ho} \text{ }^\circ\text{C}$	Discharge Time for 10 ltrs of water.	Inlet temperature $T_{ci} \text{ }^\circ\text{C}$	Outlet temperature $T_{co} \text{ }^\circ\text{C}$	Discharge time for 10 ltrs of water.

DATA-

- 1) Sp. Heat of water $=C_{pw} = 4.2 \text{ KJ/Kg K}$
- 2) Inside area of tube $= A_i = 4.5 \times 10^{-3} \times \pi \times 0.75 \times 32 = 0.34\text{m}^2$
- 3) Outside area of tubes $= A_o = 6.35 \times 10^{-3} \times \pi \times 0.75 \times 32 = 0.48\text{m}^2$
- 4) Density of water, $\rho_w = 1000 \text{ Kg/m}^3$

CACULATIONS

Heat Transfer Lab (LC –ME-314G)

1. Hot water inlet temperature $T_{hi} =$

°C Hot water outlet temperature

$T_{ho} =$ °C Cold water inlet

temperature $T_{ci} =$ °C Cold water

outlet temperature $T_{co} =$ °C

2. Mass flow rate –

Let time required for 10 ltrs. Flow of water in measuring tank for cold water be t_c and hot water be t_h ,

$$\text{Volume flow rate, } v_c = 0.01 / t_c \text{ m}^3 / \text{s}$$

$$\text{Mass flow rate, } m_c = v_c \times \rho_w \text{ Kg / s}$$

Similarly, for hot water, $m_h = v_h \times \rho_w \text{ Kg / s}$.

3. Heat collected by cold water

$$Q_c = m_c \times c_{pw} (t_{co} - t_{ci}) \quad \text{KJ / s}$$

Heat lost by hot water

$$Q_h = m_h \times c_{pw} (T_{hi} - T_{ho}) \text{ KJ / s}$$

4. Logarithmic mean temperature difference (LMTD)

For shell and tube heat exchanger,

$$\Delta T = F \times \text{LMTD}_{cf}$$

Where, $\text{LMTD}_{cf} = \text{LMTD}$ if the arrangement was counterflow,

(for 1 – shell pass and 2 – tube pass, LMTD_{cf} should be taken)

$$\text{LMTD}_{cf} = \frac{(T_{hi} - T_{co}) - (T_{ho} - T_{ci})}{\ln \left(\frac{T_{hi} - T_{co}}{T_{ho} - T_{ci}} \right)}$$

and,

F = correction factor

For finding out correction factor, values of R and S are required

$$R = \frac{T_{co} - T_{ci}}{T_{hi} - T_{ho}}$$

Heat Transfer Lab (LC –ME-314G)

$$S = T_{hi} - T_{ho} / T_{hi} - T_{ci}$$

Find out value of F from graph using values of R and S.

5. Heat transfer coefficient,

I. Inside heat transfer coefficient

$$U_i = Q_h / A_i \cdot \Delta T$$

II. Outside heat transfer coefficient

$$U_o = Q_c / A_o \cdot \Delta T$$

6. Effectiveness of heat exchanger –

$$\varepsilon = \frac{\text{Rate of heat transfer in heat exchanger}}{\text{Maximum possible heat transfer rate}}$$

$$S = \frac{h \cdot c_p \cdot (t_{hi} - t_{ho})}{m \cdot c_p (t_{hi} - t_{ci})}$$

Where, (m. c_p) is smaller of two capacity rates of m_h or m_c.

RESULTS:-

Obs. No	ΔT	U_i	U_o	ε

PRECAUTIONS:-

1. Start water supply before switching on the water heater put water heater OFF before closing the water supply.
2. Use all the controls and switches gently. Do not disturb thermocouples or wires.
3. Keep the flow rates in the prescribed range, mentioned in experimental procedure. Too low flow rate for hot water may give very high temperature, which may cause thermostat to put off the heater. Too high flow rate will give appreciable temperature rise of water.
5. Use clean water for the experiment. Water containing impurities or floating particles may clog the tubes.

Experiment No. -10

Aim: To verify the Stefan-Boltzmann constant for thermal radiation.

INTRODUCTION:

All the substances emit thermal radiation. When heat radiation is incident over a body, part of radiation is absorbed, transmitted through and reflected by the body. A surface which absorbs all thermal radiation incident over it, is called black surface. For black surface, transmissivity and reflectivity are zero and absorptivity is unity. Stefan Boltzmann Law states that emissivity of a surface is proportional to fourth power of absolute surface temperature i.e.

$$e \propto T^4$$

or $e = \epsilon \cdot \sigma \cdot T^4$
where , e = emissive power of surface

T = Absolute temperature

σ = Stefan Boltzmann Constant

ϵ = Emissivity of the surface

Value of Stefan Boltzmann constant is taken as

$$\sigma = 5.667 \times 10^{-8} \quad \text{W/ m}^2 \text{ K}^4$$

For black surface, $\epsilon = 1$, hence above equation reduces to

$$e = \sigma \cdot T^4$$

APPARATUS:

The apparatus of a water heated jacket of hemispherical shape. A copper test disc is fitted at the center of jacket. The hot water is obtained from a hot water tank, fitted to the panel, in which water is heated by an electric immersion heater. The hot water is taken around the hemisphere, so that hemisphere temperature rises. The test disc is then inserted at the center. Thermocouples are fitted inside hemisphere to average out hemisphere temperature. Another thermocouple fitted at the center of test disc measures the temperature of test disc.

A timer with a small buzzer is provided to note down the disc temperature at the time intervals of 5 seconds.

Heat Transfer Lab (LC -ME-314G)



PROCEDURE:

- See that water inlet cock of water jacket is closed and fill up sufficient water in the heater tank.
- Put ON the heater.
- Blacken the test disc with the help of lamp black and let it to cool.
- Put the thermometer and check water temperature.
- Boil the water and switch OFF the heater.
- See that drain cock of water jacket is closed and open water inlet cock.
- See that there is sufficient water above the top of hemisphere (A piezometer tube is fitted to indicate water level).
- Note down the hemisphere temperature (i.e. upto channel 1 to 4)
- Note down the test disc temperature (i.e. channel No. 5)
- Start the timer. Buzzer will start ringing. At the start of timer cycle, insert test disk into the hole at the bottom of the hemisphere.
- Note down the temperature of disc, every time the buzzer rings. Take at least 4-5 readings.

OBSERVATIONS:

HEMISPHERE TEMPERATURE (°C)	TIME INTERVAL (Sec.)	TEST DISC TEMPERATURE (°C)
T ₁ =	05	T ₅ =
T ₂ =	10	T ₅ =
T ₃ =	15	T ₅ =
T ₄ =	20	T ₅ =

Heat Transfer Lab (LC –ME-314G)

CALCULATIONS:

- Area of test disc, $A = \pi/4 \times d^2 = 3.14 \times 10^{-4} \text{ m}^2$ ($d = 20 \text{ mm}$)
- Weight of test disc, $m = 5.2 \text{ gms.} = 5.2 \times 10^{-3} \text{ kg.}$
- Plot a graph of temperature rise of disc with time as base and find out its slope at origin i.e.

$$[dT/dt] \text{ at } t = 0 \quad \text{k/sec.}$$

- Hemisphere temperature

$$T_1 + T_2 + T_3 + T_4$$

$$T_H = \dots\dots\dots + 273.15 \text{ K}$$

- Initial test disc temperature

$$T_D = T_5 + 273.15 \text{ K}$$

- As area of hemisphere is very large as compared to that of test disc, we can put

$$q = \sigma \cdot \epsilon A.$$

$(T^4 - T_D^4)$ Where, $q =$
heat gained by
disc/sec

$$= m \cdot \rho \cdot (dT/dt)$$

$\sigma =$ Stefan Boltzmann constant

$m =$ mass of test disc $= 5.2 \times 10^{-3} \text{ kg}$

$\epsilon =$ emissivity of
test disc $= 1$

$A =$ Area of disc

$\rho =$ Specific heat of copper $= 381 \text{ J/Kg } ^\circ\text{C}$

$$m \cdot \rho \cdot (dT/dt)$$

$$\epsilon = \dots\dots\dots \text{ W/m}^2 \text{ K}^4$$

$$A \cdot (T_H^4 - T_D^4)$$

Theoretical value of σ is $5.667 \times 10^{-8} \text{ W/m}^2 \text{ K}^4$

In the experiment, this value may deviate due to reasons like convection, temperature drop of hemisphere, heat losses etc.

PRECAUTIONS:

- Never put ON the heater before putting water in the tank.
- Put OFF the heater before draining the water from heater tank.
- Drain the water after completion of experiment.
- Operate all the switches and controls gently.

Viva Questions

1. What is the purpose of determining the thermal conductivity of a metallic rod or an insulating power?
2. How do you measure the thermal conductivity of a solid using the guarded hot plate method?
3. Explain the experimental setup and procedure for measuring the thermal conductivity of a metallic rod.
4. How is the effectiveness of a pin fin determined in a rectangular duct under natural and forced convection?
5. Describe the experimental setup and procedure for measuring the heat transfer rate in a channel flow using winglets.
6. What is the significance of determining the surface heat transfer coefficient for a heated vertical tube under natural convection?
7. How do you measure the local heat transfer coefficient along the length of a heated vertical tube?
8. Explain the experimental setup and procedure for measuring the average heat transfer coefficient in an externally heated horizontal pipe under forced convection.
9. What is the purpose of measuring the emissivity of a gray body (plate) at different temperatures?
10. How is the variation of emissivity with surface temperature determined and plotted?
11. What is the Stefan-Boltzmann constant, and how is it verified through experiments?
12. Compare and contrast the working of a super thermal conducting heat pipe with that of a copper pipe.
13. How is the overall heat transfer coefficient determined in a heat exchanger under parallel and counterflow conditions?
14. Describe the experimental setup and procedure for measuring the overall heat transfer coefficient and effectiveness of a heat exchanger.
15. Explain how the temperature distribution is plotted along the length of a heat exchanger in both parallel and counterflow configurations.
16. How is the temperature distribution along the length of a pin fin in a rectangular duct plotted under natural and forced convection conditions?
17. What is the procedure for measuring the temperature variation along the length of a pin fin.
18. What is the purpose of comparing experimental results with established correlations in heat transfer experiments?
19. Explain the process of comparing experimental data with correlations for externally heated horizontal pipes and vertical tubes.
20. What is the purpose of demonstrating the super thermal conducting heat pipe and comparing its working with that of a copper pipe?
21. Explain the principle behind the operation of a super thermal conducting heat pipe and how it achieves high thermal conductivity.
22. How does the working of a super thermal conducting heat pipe differ from that of a copper pipe in terms of heat transfer efficiency?
23. What are the advantages and limitations of using a super thermal conducting heat pipe compared to a copper pipe in various applications?